

Doggy Pal Collar

May 2, 2016

Group #33

Term: Spring 2016

Members:

Bryon Walsh - Electrical Engineering
Dustin DeCarlo - Electrical Engineering
Steven Heagney - Electrical Engineering
Stephanie Heagney - Electrical Engineering

Table of Contents

1.0 Executive Summary	1
2.0 Project Description.....	2
2.1 Project Motivation and Goals.....	2
2.2 Objectives	3
2.3 Requirement Specifications	4
2.3.1 Size	4
2.3.2 Weight.....	4
3.0 Research related to Project Definition	6
3.1 Related Projects	6
3.1.1 PetPace	6
3.1.2 Voyce Health Monitor	7
3.1.3 Whistle	8
3.2 Relevant Technologies	10
3.2.1 GPS sensor.....	10
3.2.2 Heart Rate Monitor Sensor	13
3.2.3 Temperature Sensor.....	16
3.2.4 Accelerometer Sensor	19
3.2.5 Wi-Fi/Bluetooth Transmitter	25
3.2.6 Power Supply	33
3.2.7 Microcontroller:	39
3.3 Microcontroller Programming.....	51
3.3.1 Code Composer Studio.....	51
3.3.2 LM Flash Programmer	53
3.3.3 Tivaware.....	53
3.3.4 Energia	54
4.0 Related Standards	56
5.0 Realistic Design Constraints	58
5.1 Economic and Time Constraints	58
5.2 Environmental, Social, and Political Constraints	60
5.3 Ethical, Health, and Safety Constraints	60
5.3.1 Animal Testing.....	61
5.4 Manufacturability and Sustainability Constraints	64

6.0 Project Hardware and Software Design Details	67
6.1 Initial Design Architectures and Related Diagrams	67
6.2 Temperature Subsystem	74
6.3 Heart Rate Monitor Subsystem	75
6.4 Accelerometer Subsystem.....	81
6.5 GPS Subsystem.....	87
6.6 Microcontroller Programming Plan	91
6.6.1 Internet of Things Subsystem.....	94
7.0 Project Prototype Construction and Coding.....	98
7.1 PCB Acquisition and BOM	98
7.2 PCB Design	98
7.3 Final Programming Code Plan	100
8.0 Project Prototype Testing	103
8.1 Temperature Sensor Testing	103
8.2 Accelerometer Testing	104
8.3 GPS Testing	104
8.4 Battery Testing.....	105
8.5 Heart Rate Monitor Testing.....	108
8.6 Wi-Fi Testing	113
8.7 Collar Stress Test.....	117
9.0 Project Plan	120
9.1 Division of Work Responsibility.....	120
9.2 Milestones.....	121
9.3 Budget.....	123
9.4 Finances	125
10.0 Project Operation.....	128
10.1 Troubleshooting the Doggy Pal Collar	130
11.0 Administrative Content	131
11.1 Works Cited.....	131
11.2 Datasheets	134
11.3 Permission Letters:.....	136

1.0 Executive Summary

Doggy Pal Collar (DPC) is a device that can be attached to a dog that is designed to monitor the heart rate, temperature, location, and position of any dog by wireless communication. This smart collar will display all the information it collects to an Internet of Things website created for the owner. The idea for this project was inspired by one of the members of the group. His dog has a medical condition that unfortunately makes his dog have erratic seizures. He explained how this condition induced constant fear because he never knew when a seizure could happen. A seizure could occur when he was away; preventing his dog from getting the required attention until it was too late. The DPC was created in the hopes that by monitoring and tracking the dog the information gained will be able to show any patterns or important signs that a veterinarian can later view and use to help treat the dog. The collar was also equipped with an alert system that can notify the owner when the dog is suffering from a seizure in real time so that the dog can get the immediate treatment he/she needs. This smart collar will detect, track, and log the dog's heart rate continuously and graph for easy access. The heart rate monitor will detect any abnormal heart rates which will alert the owner something's wrong. The temperature sensor and accelerometer will display the current temperature and position of the dog while the Internet of Things website keeps a log of all the information. The GPS element was chosen so that the owner could find the dog quickly when he/she is having a seizure or should the dog get lost. Being as this device is for a dog some abnormal design constraints need to be taken into consideration; a major one being animal testing. The University of Central Florida does not allow animals, nor humans, to be tested on so for this project some inventive substitutes using non-living objects will be sufficient. Another important constraint is the material used in the encasement of the device. It will have to be strong enough to endure some rough treatment, like withstanding being rolled on and scratched at, but the material can't be too heavy or the collar may not be able to support it. 3D printed material was chosen for its durability and lightweight. The size design of the DPC will have to be slim so that it does not disturb the dog and fits comfortably around the dog's neck, while also providing ample space for all the equipment needed. It must also meet the standards for outdoor electronic devices. The electronic components must be sealed from dirt, dust, and water. Weather is another big restraint; high temperatures, low temperatures, and humidity can become problems for both the electronic components and the design material used for the encasement. Testing will be key to ensure the DPC will operate properly under these constraints. The Doggy Pal Collar can assist veterinarians with diagnosing patients accurately by eliminating some of the guesswork that comes when treating patients that can't communicate. The creation of this smart collar will hopefully help dog owners feel more at ease knowing their best friend is not alone and that the owner can access vital information about their dog at any time or anywhere with any device that has internet access.

2.0 Project Description

The Doggy Pal Collar is a smart collar designed to monitor a dog that is wearing the collar around the neck. The smart collar is user friendly and will allow the user to monitor several important aspects about the dog at any given time. The collar will be powered by lithium-ion polymer batteries. The Doggy Pal Collar will monitor the heart rate of the dog, the temperature of the dog, the location of the dog with GPS and the position of the dog with an accelerometer. All these sensors will be on the collar around the neck in a 3D printed case that protects the components from the elements. A microcontroller will be used to connect with each sensor to process the data that is collected from each sensor. The Doggy Pal Collar will have a Wi-Fi chip on the collar that will send the data from each of these sensors to the cloud. The Internet of Things platform will be used to process and display the data in real-time using specially designed websites. These two websites are dweet.io and freeboard.io. The temperature and accelerometer data will be displayed as numeric data. The GPS data will show the location of the collar. The heart rate data will be displayed as a graph showing the pulse of the heart. If the heart rate data is abnormal, dweet.io will send a message to the user's phone alerting the user of the strange data. By having the Internet of Things platform work in unison with the hardware components, the Doggy Pal Collar can be an efficient tool for both dog owners and veterinarians to monitor and track data about a dog.

2.1 Project Motivation and Goals

The motivation for this project was to create a device that could monitor a sick dog. One member of the group has a dog that suffers from seizures. However, the seizures were random and the owner was always worried about leaving the dog alone because of these random seizures. The idea was to create a collar that can monitor the heart rate of the dog. If the dog has a seizure, the collar can alert the owner about the seizure and the owner can be aware of what is happening and go check on the status of the dog. The collar will send a message to the phone of the owner telling the owner the heart rate of the dog is abnormal. This way the owner can be away from the dog but the smart collar will always be monitoring the heart rate of the dog for any signs of seizures. The owner would also be able to track the heart rate data from the collar and be able to present that data to a veterinarian to help the veterinarian understand what is happening to the heart of the dog while a seizure is accruing. By adding in more sensors, the idea is to expand the collar into a device that can monitor several different data points about the dog. That way the owner or a veterinarian could get a lot of data about the dog from the collar instead of just the heart rate. The goal for this project became to create a collar that could monitor the heart rate, temperature, position and location of the dog. Another goal was to allow the owner or veterinarian to see the data from these sensors in real time on a device that was connected to the internet. The final goal was to have the collar send a message

to the phone of the owner if the heart rate of the dog became abnormal. By achieving these three goals a smart collar could be created that would be able to monitor the health of the dog in real-time and alert the owner in real-time if any abnormal data was collected.

2.2 Objectives

The overall objective of this project is to create an easy to use smart dog collar that will allow a user to monitor the status of a dog from anywhere an internet connection is available. To meet this overall objective, smaller objectives were created that would add up to the overall objective. The objectives listed below were determined by the project team to be important to the overall success of the Doggy Pal Collar. While some of those objectives are more important than others, each objective listed will help make the Doggy Pal Collar a success smart collar for animal lovers. To achieve this, the Doggy Pal Collar must meet the following objectives to be successful according to the team:

1. Lightweight:
 - a. The Doggy Pal Collar must be light enough for a dog to wear around the neck without causing the dog to be uncomfortable or causing physical problems.
2. Small:
 - a. Each component must be small to fit on the Doggy Pal Collar.
 - b. The dog collar must also be small so it does not get in the way of the dog's natural habits.
3. Tough:
 - a. The collar needs to be sturdy and handle the natural habits of the dog.
 - b. The collar needs to be able to handle different temperatures and weather conditions.
 - c. The components need to handle the natural habits of the dog.
 - d. The components need to handle different temperature and weather conditions.
4. Safe:
 - a. Each component must meet all safety and health requirement to be worn by a living creature.
 - b. The collar must meet safety and health requirements to be worn. The collar cannot be too tight or too loose.
5. Long Lasting:
 - a. The battery should last long and not need to be replaced frequently
 - b. The components should be long lasting and run constantly without failure.
 - c. The material used to make the collar should be long lasting without breaking.
 - d. The 3D printing material used to make the component cases should be long lasting without falling apart.

6. Accessible Data:
 - a. The owner/veterinarian should be able to access the data from the collar over the internet easily.
 - b. The data should be available at all times over the internet.
 - c. The data should be easy to read and displayed properly for each component.
 - d. The data should be updated in real-time, providing the most accurate information.
7. Smart Data:
 - a. If any data that is collected is abnormal for the dog a text message should be sent to the owner's phone alerting the owner immediately.

2.3 Requirement Specifications

The specifications will be based on the objectives outlined for this project. Therefore, while there are many different ways to approach this project and many different technologies to use, the objectives and specifications and overall scope of the project will limit the parts and technologies that can be used. The specifications will be obtained for each component of the Doggy Pal Collar. These components include the GPS unit, accelerometer, heart rate monitor, microcontroller, temperature sensor, Wi-Fi module and battery. Once these specifications are determined, the specifications for the 3D printed case and collar can be obtained. Table 2.3.1 below shows the detailed specifications for the Doggy Pal Collar.

2.3.1 Size

The overall size of the Doggy Pal Collar will be small. All of the components that will be used need to be able to fit around the neck of an average sized dog. Many different parts were researched on their size. It was important to get components as small as possible without sacrificing quality. The specifications in Table 2.3.1 for the size are the minimum requirements necessary for the project. The largest component for the Doggy Pal Collar will be the battery. The next largest will be the wireless communication module followed by the heart rate monitor. Meanwhile, the accelerometer and temperature sensor are relatively small compared to the larger components. It might be difficult to get a different battery size, therefore the battery might dictate what the specific size of the other components will be in the final design of the Doggy Pal Collar.

2.3.2 Weight

The overall weight of the Doggy Pal Collar must be as low as possible. The reasons for this are similar to the reasons for the small size of the components. Since the Doggy Pal Collar will be worn around the neck of a dog, the weight must be comfortable for the dog to carry and not cause any pain in the neck of the dog. Therefore, components were researched that would be both small in size and low in weight. These specifications were important for the overall health of the dog. Like the size specifications, Table 2.3.2-1 contains the weight specifications for the Doggy Pal Collar. The battery component is the heaviest component by far. The weight of the battery can be a more important factor than the size of the battery and the weight could be a deciding factor for which battery will be used in the final design. The 3D collar casing will also have a high weight. A different 3D material might be considered, or even a different method to hold the components if the weight of the 3D casing becomes a burden on the project.

Table 2.3.2-1 Doggy Pal Collar Component Specifications

Component Name	Size (mm) (L x W x H)	Weight (grams)
GPS Module	35.306 x 30.48 x 6.35	8.754
Accelerometer Module	21.59 x 19.05 x 2.0	1.4
Temperature Module	21 x 21 x 2	2.93
Heart Rate Module	16 x 16 x 3.2	3
Bluetooth Module	20.4 x 41 x 4	4.4
Battery (mm ³)	60 x 50 x 7.9	47
Microcontroller Module	4 x 4	1.4
Container	230 x 185 x 69	200
Collar	304.8 x 19.05	90.72

3.0 Research related to Project Definition

3.1 Related Projects

During the design ideas stage of this project the team researched different projects that were related to the same goal. These are the selected few the team deemed preeminent.

3.1.1 PetPace

The PetPace is a monitoring collar that is designed to help owners track the health of their dogs and cats via an app. It runs \$150 for the collar plus the accompanying monitoring service which costs \$15 each month. It is the first of its kind because it works for any size dog or cat. It is also the only monitoring collar that can collaborate with veterinarians so the animal can receive the best possible care. It works by wirelessly tracking the animal's vitals and sending out an alert, to both the pet owner and their veterinarian, when there seems to be a problem. The alerts come by text messages, emails or push notifications. The veterinarians are contacted by PetPace themselves to "provide education about the system and set them up to receive its alerts". Veterinarians receive part of the revenue from the monitoring service, according to PetPace. It can also track a range of physical and behavioral parameters, activity patterns, and pain. The collar monitors the dog's or cat's body posture and follows trends in order to identify pain or the recovery process from injuries. This collar also tracks how many calories your pet has burned for weight loss information to help prevent obesity. The earlier health issues like diseases are detected the easier it is to prevent suffering and significantly reduce health-related medical bills. It is hard to diagnose a pet because they are unable to communicate their health problems and pains so they often remain hidden. PetPace was designed to alleviate that as co-founder and chief executive of PetPace, Avi Menkes, says "This is the first system that can actually let the pet talk to us".

Collar Specifications:

- Single push-button interface
- LED indications
- IP-67 water & dust resistance
- Shockproof and ruggedized for outdoor use
- Dimensions: (electronics case) 1.57 x 1.27 x 0.59" (40 x 35 x 15mm)

- Weight: 1.5oz(43gr)
- Battery: LiPo 250mAh, for over 6 weeks between recharges
- Adjustable strap, available in 3 sizes: S,M,L
- Fits pets over 8 lbs
- Rechargeable collar

Gateway Specifications:

- LED indications
- Standard micro-USB connector for power
- Ethernet 10/100 BASE-T
- Single gateway can serve up to 30 collars
- Dimensions: 3.07 x 2.11 x 2.00" (78 x 60 x 51mm)
- Weight: 2.18oz (62g)

3.1.2 Voyce Health Monitor

The Voyce Health Monitor is an award winning collar that was “developed in collaboration with biomedical engineers, veterinary experts and Cornell University College of Veterinary Medicine”. This collar uses non-invasive sensors that can detect various health conditions, behavior issues, heart disease and anxiety for preventative care at any age.

How Voyce is able to reveal so much is by monitoring key features which include:

- Resting Heart Rate
- Resting Respiratory Rate
- Activity & Intensity
- Quality of Rest
- Calories Burned
- Distance Traveled

Resting heart and respiratory rate gives crucial information that can lead to early detection of health issues and lower medical costs. Both the resting heart rate and respiratory rate are tracked by the Health Monitor while the dog is at completely at rest by taking multiple reading of both the carotid pulse and muscle movement in the neck. The reading are then averaged to minimize heart rate variability and increase accuracy; then graphed over time so trends are easily visible. This smart collar creates a vital sign baseline for owners and veterinarians so that they can easily detect and address changes in health and behavior. The Voyce Health Monitor costs \$199 plus \$9.50 a month to access your dog's data, tailored articles and resources like advice from pet experts that is tailored specifically to each individual dog. The owner can also; get a customized dashboard with fast facts, and articles based their dog's breed and health profile; set goals to encourage more active, spur weight-loss, and spend more quality time together; set reminders for vaccines, flea and tick shots, ear cleaning or clipping toenails, upcoming appointments, etc.

Collar Specifications

- Ergonomic curved design
- Lightweight, less than 6 ounces including the band
- Multiple sizes accommodate 12-32 inch necks
- Easy to use multi-function button and LED
- Durable, dust proof, and waterproof up to 1 meter (Rated to IP67)
- Non-invasive, radio frequency based technology

- Fully integrated triple axis accelerometer
- Powerful onboard microcontroller
- Proprietary, specialized algorithms analyze data
- Rechargeable lithium-ion polymer battery
- Portable charging station utilizing micro-USB
- Estimated normal use of up to one week between charges

Connectivity Specifications:

- Optimized for all current major browsers on desktops, tablets, and smartphones
- Requires Internet access and Wi-Fi connectivity for syncing (802.11 b/g/n at 2.4 GHz)
- Supports up to 10 separate networks

3.1.3 Whistle

Whistle has two products, the first originally named Whistle GPS Pet Tracker is solely a GPS tracker and the second named Whistle Activity Monitor that tracks a pet's health. The GPS Pet Tracker is priced at \$79.95 each plus a required monthly fee that ranges from \$6.95 - \$9.95 in order to activate while the Activity Monitor is priced at \$99.95 with no monthly fee. The Whistle GPS Pet Tracker will send the dog's information to the owner's smartphone via an app. It is first device to combine an app system and location-tracking with smart activity monitoring.

This smart collar features:

- Live GPS Tracking
- Location alerts
- Nationwide GPS Coverage
- Custom Whistle zones
- Monitor health trends
- Track progress
- Connected caretakers

Whistle zones are customized safe areas that the owner can choose and receive alerts when their pet leaves that area. The owner can also track their dog's long-term health trends and compare the information with the shape for the dog's age, weight, and breed. Everyone who has a hand in caring for the dog can be added to the owner's account; that way everyone's always informed.

Whistle GPS Pet Tracker Specifications

- Rechargeable battery - a full recharge only takes an hour.
- Durable - rated IP67
- Waterproof

Technical Specifications:

- Dimensions: 1.5 x 4.2 x 0.8 inches
- Weight: 1.3 ounces
- Waterproof (IP67)
- Collar Attachment (attaches to any collar and harness up to 1" wide)

Software Compatibility:

- Apple iOS 7.1 or greater
- Android 4.0.3 or greater
- Web app available for desktop and mobile browsers

The Whistle Activity Monitor will also send information to the owner's smartphone via an app. This make it easy for the owner to create healthy habits and track their dog's progress. The device attaches to the dog's existing collar and starts tracking the daily activity and long-term health trends.

This smart collar features:

- Activity tracking
- Set a custom goal
- Track progress
- Stay connected when away
- Compare to similar dogs
- Track medication
- Monitor health trends
- Log food intake

Whistle Activity Monitor also allows the owner to add others to their account so everyone can communicate about medication, meals, and other details. Within the Whistle app there is the Whistle Community, a communication hub for owners to share photos, notes, and memories like themselves. Just like Twitter and Facebook; owners are able to share their adventures, follow friends and compare their dog's stats with similar dogs.

Whistle Activity Monitor Specifications:

- 3-axis accelerometer
- LED indicators
- Single push-button interface
- Waterproof (IPX-7)
- Shockproof and ruggedized
- Dimensions: 38 mm W x 10 mm H
- Weight: 16 g
- Adjustable strap, compatible with all collars
- Fits dogs over 10 pounds
- Built-in rechargeable lithium-ion polymer battery
- Up to a week between charges
- USB charging dock

Wireless Connectivity:

- Bluetooth 4.0 Dual Mode (Classic and Low Energy)
- Wi-Fi 802.11 b/g/n (2.4GHz supported)

Software Compatibility:

- Apple iOS 7.1 or greater
- Android 4.0.3 or greater

3.2 Relevant Technologies

3.2.1 GPS sensor

Ultimate GPS Module - MTK3339 chipset: The MTK3339 chipset is a high-sensitivity receiver, high-quality, no-nonsense GPS module that can track up to 22 satellites on 66 channels. It has a built in antenna and has a high speed of 10 location updates per second. Plus, the power consumption is incredibly low at only 20 mA during navigation. Its two best features are the external antenna functionality and the built in data-logging ability. If a bigger antenna is needed it can easily attach to the "ANT" pad and the module will automatically detect the new antenna and switch over. In order for the built in data-logging to start a microcontroller is needed to send a "Start Logging" command. Once the command has been sent "the time, date, longitude, latitude, and height is logged every 15 seconds and only when there is a fix". The MTK3339 chipset can store up to 16 hours of data and updates data automatically so there is no worry about losing data if the power is lost. It costs \$29.95 on the Adafruit website.

Other features include:

- -165 dBm sensitivity, 10 Hz updates, 66 channels
- MTK3339 Operating current: 25mA tracking, 20 mA current draw during navigation
- 3.3V operation,
- RTC battery-compatible
- Built-in data-logging
- PPS output on fix
- Works up to ~32 Km altitude (the GPS theoretically does not have a limit until 40Km)
- Internal patch antenna + connection for optional external active antenna
- Fix status output
- Ultra-small size: only 16mm x 16mm x 5mm and 4 grams
- Satellites: 22 tracking, 66 searching
- Update rate: 1 to 10 Hz
- Position Accuracy: < 3 meters (all GPS technology has about 3m accuracy)
- Velocity Accuracy: 0.1 meters/s
- Warm/cold start: 34 seconds
- Acquisition sensitivity: -145 dBm

- Maximum Velocity: 515m/s
- Vin range: 3.0-4.3VDC
- Output: NMEA 0183, 9600 baud default
- DGPS/WAAS/EGNOS supported
- FCC E911 compliance and AGPS support (Offline mode : EPO valid up to 14 days)
- Up to 210 PRN channels
- Jammer detection and reduction
- Multi-path detection and compensation

GPS Receiver - GP-2106 SiRF IV: The GP-2106 is another small quarter sized GPS receiver with a built-in high sensitivity sensor, and smart antenna. This module can detect satellites as low as -163dBm and is powered by the SiRF Star IV GPS solution. It also come with the ability to go as low as 30uA while in hibernate mode and still maintaining a hot start. This 48 channel GPS module works best when it is embedded in portable devices like car tracking device, locator application, and safety alarm devices to only name a few. The embedded active Jammer remover will ensure fast and accurate navigation even if it's in unfavorable signal/high noise environments. This GP-2106 GPS receiver can be found on the Sparkfun website for \$49.95.

Other features include:

- SiRF IV chipset (3db gain over SiRF III)
- 48 channel
- Cold start - 35 second
- Warm start - 35 second
- Hot start - 1 second
- 1Hz update rate
- 1.8VCC input
- 4800bps (default)
- Wire to board connector type
- Support MEMS Sensor to detection and wakeup the device for power saving and longer battery life.
- Adaptive Micro-power controller- only 50 to 500uA to maintain hot start capability.
- Embedded Instant Fix CGEE and Reverse CGEE (3 days) for faster warm start.
- Embedded active Jammer remover to ensure fast and accurate navigation in hostile signal environments – GSM, NB environments

Garmin GPS 15x™: This GPS is a functional, high-sensitivity sensor that is designed for a variety of OEM applications like car navigation, wireless communication, marine navigation and mapping. It is ideal for projects that have a limited amount of space because its size is practically the size of a commemorative stamp and its weight is 0.26 ounces. Also because of its small size it can be remotely mounted in out-of-the-way locations. This GPS sensor has a CMOS level, UART-compatible asynchronous serial port, a wide input

voltage range, can be updated with the latest firmware from the Garmin website, and offers excellent EMI/RFI performance so the user doesn't have to worry about interference while operating it near smart mobile devices and wireless communications equipment. Using its proven technology that is found in other Garmin GPS receivers, GPS 15x™ is designed with a spectrum of OEM (Original Equipment Manufacturer) system applications that can track multiple satellites at a time while providing fast time-to-first-fix, precise navigation updates, and low power consumption. The GPS 15x™ also has the capability of Wide Area Augmentation System (WAAS) differential GPS and can be supplied by an OEM or system integrator with only a few additional components. It is available on the Garmin website for \$43.50.

Other features include:

- GPS receiver tracks and uses multiple satellites for fast, accurate positioning and velocity estimates.
- Compact, rugged design ideal for applications with minimal space.
- May be remotely mounted in an out-of-the-way location.
- User initialization is not required. Once installed, this device automatically produces navigation data.
- On-board backup battery to maintain the non-volatile SRAM and real-time clock for up to 21 days.
- Provision for external power to maintain the charge on the backup battery.
- Configurable parameters include expected position, current time and date, and preferred position fix type (2D, 3D, or automatic)
- Size - 0.940 × 1.690 × 0.309 in. (23.88 × 42.93 × 7.84 mm)
- Weight - 0.26oz. (7.37g)

For the Doggy Pal Collar the GPS needs to meet specific requirements. As this device is going to be worn around a dog's neck it needs to be small and light weight which includes the GPS chip. It also needs to have high-sensitivity because the dog may travel in places where signal interference could be a factor. It also needs to be cheap due to budget restraints. The Adafruit MTK3339 chip meets all the requirements and more. Its low power consumption means less battery power is needed which leads to a smaller battery; inadvertently lowering the overall weight of the device. It uses UART interface and Adafruit tested this GPS chip themselves and found the time-to-first-fix to be 45 seconds in Downtown Manhattan, New York. This chip was capable of tracking them as they traveled through New York's underground caverns, which is impressive. Even though the MTK3339 is small and therefore has a small flash there is an option to program the chip to only log information when moving which saves flash space. For these reasons the Adafruit's MTK3339 GPS chip, shown in Figure 3.2.1-1, was chosen to be implemented into the smart collar.

Figure 3.2.1-1: MTK3339 GPS Chip (Courtesy of Adafruit)



3.2.2 Heart Rate Monitor Sensor

The MAX30100 is a pulse oximeter and heart-rate monitor integrated chip sensor created by Maxim Integrated. The MAX30100 comes with two light emitting diodes, a photodetector sensor, enhanced optics and low frequency noise analog signal processing that can be used to find pulse oximetry and heart-rate signals. The sensor can run on a power supply of 1.8V or a power supply of 3.3V. The sensor can run at a temperature of -40°C to +85°C. Using software, the sensor can be powered down with little standby current which allows the power supply to remain attached. This type of sensor can be used for medical devices, wearable clothing and fitness devices. According to the MAX30100 datasheet, the sensor has the following features and benefits:

1. Complete Pulse Oximeter and Heart-Rate Sensor Solution Simplifies Design
 - a. Integrated LEDs, Photo Sensor, and High-Performance Analog Front -End
 - b. Tiny 5.6mm x 2.8mm x 1.2mm 14-Pin Optically Enhanced System-in-Package
2. Ultra-Low-Power Operation Increases Battery Life for Wearable Devices
 - a. Programmable Sample Rate and LED Current for Power Savings
 - b. Ultra-Low Shutdown Current (0.7 μ A, typ)
3. Advanced Functionality Improves Measurement Performance
 - a. High SNR Provides Robust Motion Artifact Resilience
 - b. Integrated Ambient Light Cancellation

- c. High Sample Rate Capability
- d. Fast Data Output Capability

The AFE4400 is an analog front-end integrated chip sensor used for pulse oximeter devices. The sensor has a low frequency noise receiver channel with an analog-to-digital converter that is integrated into the chip, a light emitting diode transmit section and diagnostics for sensor fault detection and light emitting diode fault detection.

The AFE4400 sensor also acts as a flexible timing controller. This ability allows the user to have total control of the AFE4400 timing characteristics. The device also has an integrated oscillator that runs from an external crystal. This oscillator eases clocking requirements and provides a low-jitter clock to the device. The AFE4400 talks to external devices, such as a microcontroller, using an SPI™ interface. Applications for the AFE4400 include medical devices and optical devices. According to the AFE4400 datasheet, the sensor has the following key features:

1. Fully-Integrated Analog Front-End for Pulse Oximeter Applications:
 - a. Flexible Pulse Sequencing and Timing Control
2. Transmit:
 - a. Integrated LED Driver (H-Bridge, Push, or Pull)
 - b. Dynamic Range: 95 dB
 - c. LED Current:
 - i. Programmable to 50 mA with 8-Bit Current Resolution
 - d. Low Power:
 - i. 100 μ A + Average LED Current
 - e. Programmable LED On-Time
 - f. Independent LED2 and LED1 Current Reference
3. Receive Channel with High Dynamic Range:
 - a. 13 Noise-Free Bits
 - b. Low Power: < 670 μ A at 3.3-V Supply
 - c. Integrated Digital Ambient Estimation and Subtraction
 - d. Flexible Receive Sample Time
 - e. Flexible Trans impedance Amplifier with Programmable LED Settings
4. Integrated Fault Diagnostics:
 - a. Photodiode and LED Open and Short Detection
 - b. Cable On and Off Detection
5. Supplies:
 - a. Rx = 2.0 V to 3.6 V
 - b. Tx = 3.0 V to 5.25 V
6. Package: Compact VQFN-40 (6 mm \times 6 mm)
7. Specified Temperature Range: 0°C to 70°C

The AD8232 is a signal conditioning integrated chip used for ECG measurement applications. The chip is created to receive, amplify and filter bio potential signals that are within noisy conditions. This type of design allows for other devices such

as a microcontroller or an ultralow power analog-to-digital converter to receive output signals easily. The chip can implement a two-pole high-pass filter that in combination with instrumentation architecture of the amplifier can allow both large gain filtering and high-pass filtering in a single stage. This ability saves both space and cost. The AD8232 also has a fast restore ability that reduces the length of settling tails from the high-pass filter. Using an uncommitted operational amplifier, the chip can create a three-pole low-pass filter to eliminate more noise. Depending on the application type, the user can choose the frequency cutoff of all filters. The AD8232 has an amplifier for driven lead applications to help improve common-mode rejection of interferences. One example would be right leg drive (RLD). The chip performance temperature is from 0°C to 70°C and its operational temperature is from -40°C to +85°C. Applications for the AD8232 integrated chip include medical devices, fitness devices and gaming devices. According to the AD8232 datasheet, the chip has the following features:

1. Fully integrated single-lead ECG front end
2. Common-mode rejection ratio: 80 dB (dc to 60Hz)
3. Low supply current: 170 μ A (typical)
4. Two or three electrode configurations
5. High signal gain ($G = 100$) with dc blocking capabilities
6. 2-pole adjustable high-pass filter
7. Accepts up to ± 300 mV of half-cell potential
8. Uncommitted op amp
9. Fast restore feature improves filter settling
10. 3-pole adjustable low-pass filter with adjustable gain
11. Leads off detection: ac or dc options
12. Single-supply operation: 2.0 V to 3.5 V
13. Integrated right leg drive (RLD) amplifier
14. Integrated reference buffer generates virtual ground
15. Rail-to-rail output
16. Internal RFI filter
17. Shutdown pin
18. 8 kV HBM ESD rating
19. 20-lead 4 mm \times 4 mm LFCSP package

The MAX30100, AFE4400 and AD8232 each have their advantages and disadvantages. Some features of each chip will not be necessary for the Doggy Pal Collar, but each chip would bring something different to the Doggy Pal Collar and each chip is a good choice for a heart rate monitor which is a key part of the project. However, because of the constraints and specifications needed for the Doggy Pal Collar, each integrated chip will have to be weighed against those requirements and the integrated chip that best meets those requirements for the project will be chosen. The decision was made to use the AD8232 integrated chip for the heart rate monitor sensor for the Doggy Pal Collar. This chip was chosen because the features of the AD8232 match well with the requirements for the Doggy Pal Collar. The AD8232 integrated chip needs a low supply current at typically 170 μ A and is small in size at 4 mm \times 4 mm. This will be helpful because

the components of the Doggy Pal Collar need to run at low power and be small in size to fit on the collar. It also has a single-lead front end and flexible analog filter features that will help filter out noise and take good measurements of the heart-rate. The AD8232 can also be paired with a microcontroller to make viewing output data easy and will work alongside an electrode cable. The AD8232 comes with a shutdown pin that can put the chip into a low power shutdown mode. In this mode the chip draws less than 200 nA of current. It also has a leads off comparator output which has both DC and AC detection modes. If an electrode is removed from the body it will cause the leads off pin to display a flat line. This helps with easy trouble shooting and can warn the user that the heart rate monitor is not functioning properly. While the MAX30100 and the AFE4400 are good integrated chips, the features of the AD8232 show that the chip was built for small, portable medical devices and this will be useful for the Doggy Pal Collar. Figure 3.2.2-1 shows the pin configuration of the AD8232 chip from Analog Devices.

While the AD8232 is a good chip, for the final design the Pulse Sensor Amped was chosen. The Pulse Sensor Amped is a plug and play heart rate sensor device that is easy to use for prototyping and testing. The Pulse Sensor Amped at its heart is an optical heart rate sensor and uses pulse oximetry to find the heart rate. It also comes with built in amplification and noise cancellation circuit technology to help get an accurate reading. Another bonus is the sensor only uses 4mA current draw and 5v making it a great sensor for a mobile and low powered device like the Doggy Pal Collar. The size of the sensor is another great feature because its small size saves a lot of space for bigger components of the Doggy Pal Collar. Overall, from the beginning of the project to the end, the Pulse Sensor Amped had multiple advantages over the competition for this project.

3.2.3 Temperature Sensor

The TMP007 is an infrared temperature sensor integrated chip made by Texas Instruments. The features listed on its datasheet are:

- Integrated MEMS Thermopile for Noncontact Temperature Sensing
- 14-bit Local Temperature Sensor for Cold Junction References
 - +/- 1 ° C (max) from 0 ° to +60 ° C
 - +/- 1.5 ° C (max) from -40 ° to + 125 ° C
- Integrated Math Engine
 - Directly Read Object Temperature
 - Programmable Alerts
 - Nonvolatile Memory for Storing Calibration Coefficients
 - Transient Correction
- Two-Wire Serial Interface Options
 - I²C and SMBus Compatible

- o Eight Programmable Addresses
- Low Power
 - o Supply: 2.5 V to 5.5 V
 - o Active Current: 270 μ A (typ)
 - o 2- μ A shutdown (max)
- Compact Package
 - o 1.9-mm x 1.9-mm x 0.625-mm DSBGA

(Texas Instruments, TMP007 Infrared Thermopile Sensor with Integrated Math Engine)

The TMP007 measures temperature without contact by absorbing passive infrared energy from its target object. The math engine uses the voltage change across the thermopile along with its reference to obtain the target object's temperature. The TMP007 can operate at temperatures from -40° to $+125^{\circ}$ C, and can measure beyond that range as long as the sensor itself stays within the operating temperature range. A functional block diagram of the TMP007 can be seen in figure TMP1. The TMP007 is an 8-pin integrated circuit; its pin configuration can be seen in figure TMP2. The pin designations can be found in table TMP1.

Two of the typical characteristics of the TMP007 that are important for this project are the response of the chip to particular wavelengths, and the response of the chip based on the viewing angle it has on its target. A plot of the response ratio of the chip versus the wavelength in μ m is shown in figure TMP3. A plot of the Responsivity of the TMP007 versus the viewing angle to the target is shown in figure TMP4. For this project, the TMP007 will need to be pointed directly towards the target to achieve the optimum response. The TMP007 will be positioned on the printed circuit board closest to the inside of the collar, with a small viewing port which will let it have a direct 0° viewing angle to the temperature measurement target. The wavelengths shown in figure TMP3 are the wavelengths of maximum sensitivity for the TMP007. The chip is engineered to sense infrared radiation emitted from objects in the range of -23° C to 127° C. Even if most of the infrared emission from the body heat of the target is outside of the wavelengths of maximum sensitivity for the TMP007, the chip will still get a reading. The chip features internal calibration coefficients to compensate for environmental factors and sensor characteristics. According to the datasheet, the device should be recalibrated if the board layout is changed, object distance or angle is changed, the supply voltage is changed, or the environment changes significantly. The sensor can be calibrated once in the prototype stage in order to factor out the heat from surrounding components or ambient heat of the environment. The object distance will remain constant once the sensor is mounted on the printed circuit board and installed into the prototype housing (Texas Instruments, TMP007 Infrared Thermopile Sensor with Integrated Math Engine).

The TMP007 appears to be a very good choice for the temperature sensor in this project. The no-contact temperature reading ability of the device negates

concerns about fur or hair obstructing readings. Concerns about maintaining constant physical contact with the measurement target are also avoided. The extremely small size of the device is very well suited to the wearable nature of this project. The TMP007 is available for \$4.75 directly from the Texas Instruments website, store.ti.com.

Figure 3.2.3-1: TMP007 Pin Configuration (Courtesy of Texas Instruments)

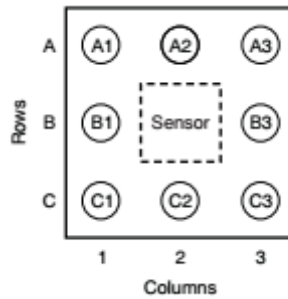

Table 3.2.3-1: Pins of the TMP007:

Pin Name	Pin Number	Function
ADR0	C1	Input Address 0 Select
ADR1	B1	Input Address 1 Select
AGND	A2	Analog Ground
ALERT	C2	Alert Output, Active Low
DGND	A1	Digital Ground
SCL	B3	Input Clock Pin
SDA	C3	Data I/O
V+	A3	Supply Voltage (2.5 V to 5.5 V)

Figure 3.2.3-2: Response vs Wavelength (Courtesy of Texas Instruments)

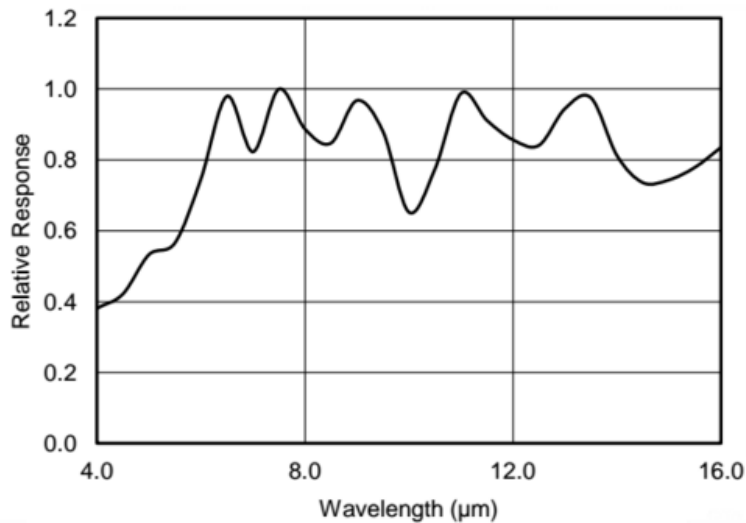
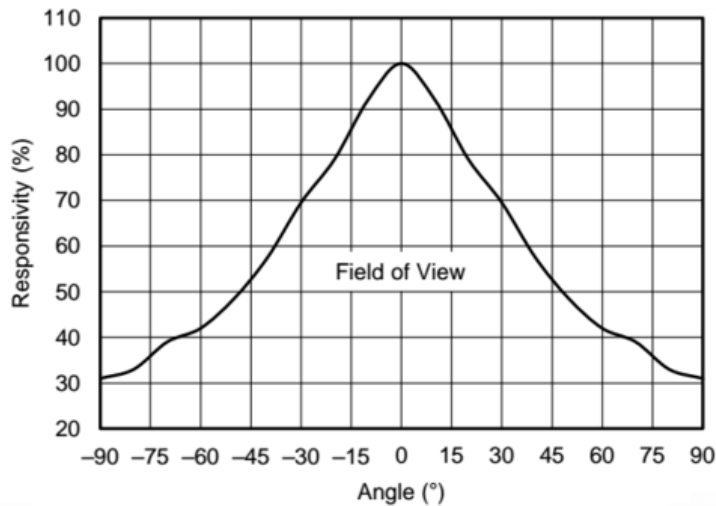

Figure 3.2.3-3: Response vs Angle (Courtesy of Texas Instruments)



3.2.4 Accelerometer Sensor

The accelerometer on this device is possibly the most important component for this product. When the team sat down and discussed this module it was decided to choose the best design on the market. It was decided overall that the group could sacrifice some specification on other modules to amplify the usefulness of the overall design.

The accelerometer on the Doggy Pal Collar is the overall input of information of the design. When reviewing all the items it was found that 90% of the inputs will come from the accelerometer, and the more information the team have the more the microcontroller was able to conclude from what is given.

The amount of power consumed by this component is extremely important. Unlike other components like the Wi-Fi that runs only when in use the accelerometer is constantly running and gathering information, so it is imperative that the power consumption for this module is a minimum to increase the longevity of the device.

When reviewing these devices the team found they were extremely cheap compared to the other components within the system. Due to its importance the group found the cost to be unimportant compared to the amount of information and accuracy that the team can obtain therefore the team was searching primarily for the best device on the market.

Accelerometer Sensor #1: The Kionix 2 / 3 Axis Accelerometer was the first device analyzed as seen in Figure 3.2.4-1. This accelerometer is cheap, has a good operation temperature range up to 85 degrees Celsius and has a low operation range. It was decided not to use this device because it only produces 3 axis of information. The team would have to attach at least 1 more to get role information and other Axis of pull.

Figure 3.2.4-1: Kionix Accelerometer (Courtesy of Kionix)

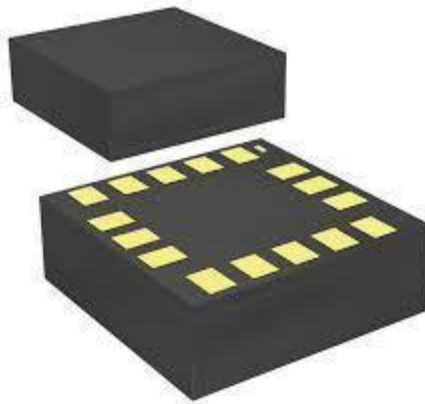

- Sensing Axis: X, Y, Z
- Acceleration: 2 g, 4 g, 6 g, 8 g
- Sensitivity: 256 count/g, 341 count/g, 512 count/g, 1024 count/g
- Output Type: Digital

- Interface Type: I2C
- Resolution: 12 bit
- Supply Voltage - Max: 3.6 V
- Supply Voltage - Min: 1.7 V
- Package / Case: LGA-16
- Maximum Operating Temperature: + 85 C
- Minimum Operating Temperature: - 40 C
- Axes: 3

Accelerometer Sensor #2: The second accelerometer that was tested is the GY-52 3 Axis + Gyroscope for Arduino as seen in Figure 3.2.4-2. The main problem with this module is that it is for Arduino. Arduino type microcontrollers are bulky and run at high power outputs which are non-ideal for our design. This type of device was great for us because of the amount of information that the team could gather, but unfortunately this type of microcontroller is unwanted in our design.

Figure 3.2.4-2 – GY-52 Accelerometer (Courtesy of Dealextreme)

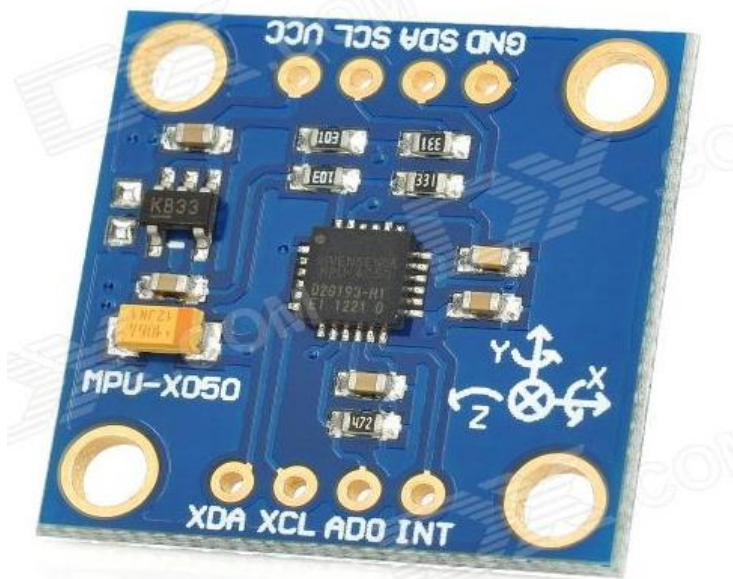

- Sensing Axis: X, Y, Z, Gyroscope 9 axis total
- Acceleration: 2 g, 4 g, 6 g, 8 g, 16g

- Gyroscope Range: 250, 500, 1000, 2000 Degrees
- Sensitivity: 256 count/g, 341 count/g, 512 count/g, 1024 count/g
- Output Type: Digital
- Interface Type: I2C
- Resolution: 12 bit
- Supply Voltage - Max: 5 V
- Supply Voltage - Min: 3 V
- Maximum Operating Temperature: + 85 C
- Minimum Operating Temperature: - 40 C

Accelerometer Sensor #3: The third accelerometer looked at is the Freescale FXLS8471Q 3 Axis accelerometer as seen in Figure 3.2.4-3. The team was interested in this device because of its low voltage requirement. When the design was overlooked the team found that this accelerometer is large and bulky for what the group needed. The size of the device is an overall reason to conclude that this device is unwanted.

Figure 3.2.4-3 Freescale Accelerometer (Courtesy of NXP)

FXLS8471Q Freescale Accelerometer Breakout Board

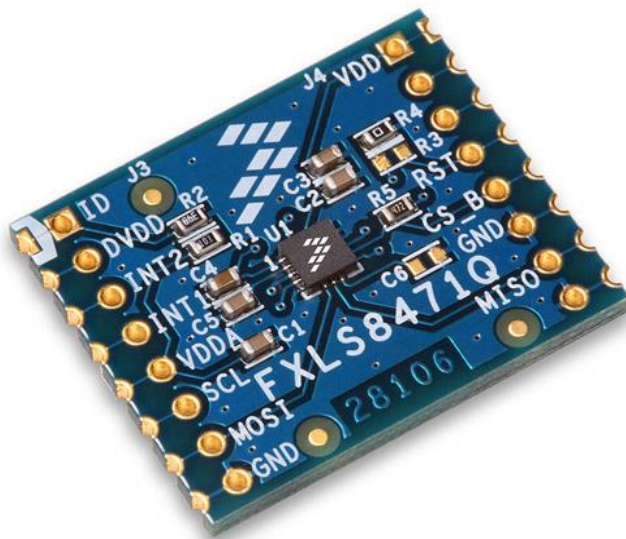

- Sensing Axis: X, Y, Z
- Acceleration: 2 g, 4 g, 6 g, 8 g
- Output Rates: 1.56 to 800 Hz
- Output Type: Digital
- Interface Type: I2C
- Resolution: 12 bit
- Supply Voltage - Max: 3.6 V
- Supply Voltage - Min: 1.95 V
- Package / Case: LGA-16
- Maximum Operating Temperature: + 85 C
- Minimum Operating Temperature: - 40 C

Accelerometer Sensor #4: It was recommended by our professor to use the Invensense accelerometer due to its specifications. This accelerometer is the most advanced the team had looked at. It has a low running voltage and it was found to give us the most information out of any device. In addition it comes with a built in thermometer in which the team can use as a reference temperature for our animal temperature sensor.

- Sensing Axis: X, Y, Z, Compass, rotational
- Acceleration: 2 g, 4 g, 6 g, 8 g, 16g
- Sensitivity: 256 count/g, 341 count/g, 512 count/g, 1024 count/g
- Output Type: Digital
- Interface Type: I2C
- Resolution: 12 bit
- Supply Voltage - Max: 3.6 V
- Supply Voltage - Min: 1.7 V
- Package / Case: LGA-16
- Maximum Operating Temperature: + 85 C

Temperature:

- Minimum Operating Temperature: - 40 C

Invensense Accelerometer Figure 3.2.4-4 (Courtesy of Invensense)

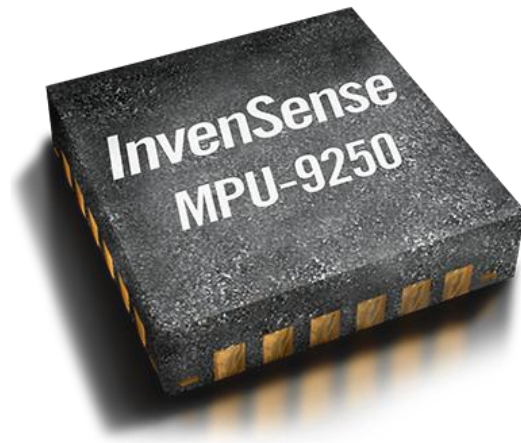

It was decided to go with the Invensense 9250. As a group it was chosen to use this device because it exhibited the best qualities overall. The Invensense had 6 axis of sensitivity and 3 separate compass for the x y z plane. The Kionix accelerometer was cheap and small, but its temperature operation range was unacceptable, being that it could only operate up to temperatures of 80 Celsius as under a collar for extended periods of time it is possible to reach these temperatures. The second accelerometer tested was the GY. This accelerometer was cheap and within the performance standards of our design, but unfortunately it was designed for an Arduino microcontroller. It was decided to find an accelerometer with these type of specifications but one that could operate with our microcontroller. The third accelerometer that was tested is the Freescale. It was decided to analyze this device because of its low voltage requirement. This device only had 3 axis of sensitivity but it was considered to run two of these devices simultaneously because of the low cost and operational voltage needed. The Invensense accelerometer not only had 6 axis of total sensitivity, it also has a built in thermometer which can be used as a secondary reference thermometer. After testing and assembling the device it ran beyond expectations. The Invensense accelerometer was clearly the better quality component to use based on both the price of the unit and the many features the unit comes with.

For the final project it was decided to use the Adafruit MMA8451 Accelerometer. This device uses the Freescale Xtrinsic MMA8451Q accelerometer chip at its heart. The chip is low-powered, has three-axis and 14 bits of resolution. It uses

1.95V to 3.6V of power which is helpful to keep the Doggy Pal Collar battery lasting longer. It has I²C digital output interface and two programmable interrupt pins for an inertial wakeup mode. Overall, it was a great sensor for the project.

3.2.5 Wi-Fi/Bluetooth Transmitter

Wi-Fi Adapter #1: The first device that was looked at was the Tiny UART Embedded Module Wi-Fi system. As you can see from the figure below (Figure 3.2.5-1) this device is extremely large. The team's goal was to try to keep the dog collar as small as possible so the team determined this to be problematic for the design. Had this device been smaller it would have been more ideal to use. The next problem that was found with the device was the amount of power that it consumed. This module required 3.3v for usage.

Figure 3.2.5-1 Tiny UART (Courtesy of gridconnect)



Below are a list of specifications for the Tiny UART Embedded Module:

- Cost: \$12.98
- Frequency Band: 2.4 GHz
- Protocols: TCP/IP/UDP/FTP/HTTP
- Dimensions: 22 x 13.5 x 6 mm (10x1 2mm DIP)
- Power Consumption: Continuous TX: ~200mA, Normal (Ave): ~12mA ; Peak 200mA, Standby: <200uA
- Voltage Requirement: 3.3V
- Temperature operation range: Operation: -40°C to 85°C (-40°F to 185°F)

Wi-Fi Adapter #2: The second device that was looked at was the Wi-Fi shield wishield v2.0 for the Arduino as seen in Figure 3.2.5-2. The first problem with this device was that it runs with an Arduino, but it was decided to analyze this product to make sure it is something to use or not use. After looking it over it was decided that this device was massive and not realistically usable. The next problem that was found with this device was that the power consumption is high. This device runs at 5 volts which is 2 volts higher than the first device making this

no longer an option. Obviously one advantage of this Arduino system is its compatibility and ease of use. Unfortunately I believe it would create a massive device with high power consumption over time. This system is good for the new electronics user but not for our design.

Figure 3.2.5-2 wishield v2.0 (Permission Pending from LinkSprite)



Below are some specifications for the

- Cost: \$12.98
- Frequency Band: 2.4 GHz
- Protocols: TCP/IP/UDP/FTP/HTTP
- Dimensions: 22 x 13.5 x 6 mm (10x1 2mm DIP)
- Power Consumption: Continuous TX: ~200mA, Normal (Ave): ~12mA ; Peak 200mA, Standby: <200uA
- Voltage Requirement: 5V
- Temperature operation range: Operation: -40°C to 85°C (-40°F to 185°F)
- 802.11b Wi-Fi certified
- 1Mbps and 2Mbps throughput speeds
- Ability to create secured and unsecured networks
- WEP (64-bit and 128-bit)
- Sleep mode: 250µA
- Transmit: 230mA
- Receive: 85mA

Wi-Fi Adapter #3: The third device that was looked at was the Olimex Wi-Fi Adapter as seen in Figure 3.2.5-3. The device looked good at first glance. This device was cheap, less than 10 dollars making it quite ideal for mass production. The temperature range was identified as being inadequate. The maximum range for the temperature is 70 degrees Celsius making it less likely to survive extended use in Florida. The Wi-Fi adapter would be under the plastic/rubber

material of the collar but the collar itself will be black. Since black rubber/plastic really heats up fast we found this Wi-Fi adapter unusable.

Figure 3.2.5-3 Olimex Wi-Fi Adapter (Permission Pending from Olimex)



Some specifications of the Olimex Wi-Fi Adapter are as follows:

- Cost: \$9.99
- Frequency Band: 2.4 GHz
- Protocols: TCP/IP/UDP/FTP/HTTP
- Voltage Requirement: 3.3V
- Temperature operation range: Operation: -40°C to 70°C
- 802.11b Wi-Fi certified
- Transmit: 215mA
- Receive: 62mA

It was decided to look at the CC3100 as our Wi-Fi Adapter because of its versatility, size, weight, and specifications. Figure 3.2.5-4 is a picture of the CC3100. Although these are general reasons, this device goes far beyond the needed requirements. This device can connect to just about any microcontroller that is 8, 16 or 32 bit. Below are some of the standard specifications for this. This is a Wi-Fi Certified chip. The internal Clock runs at 32.768 KHz with a startup time of 250ms.

- Internal clock is 32.768 KHz
- Initialization Time is 250 ms
- Wi-Fi certified chip
- 802.11 b/g/n Radio, Baseband, and Medium Access Control (MAC)
- Interfaces with 8, 16 and 32 bit MCU's

- Integrated DC/DC supply voltage
- Operates from 2.1V to 3.6V
- Pre Regulated 1.85V
- Low voltage deep sleep mode runs at 115 Microamps.
- Clock source is a 40 MHz crystal with an internal oscillator
- Ambient temperature range of -40 to 85 Celsius

Figure 3.2.5-4: CC3100 Unit (Courtesy of Texas Instruments)



In conclusion the team decided to use the Texas Instruments CC3100 as our final Wi-Fi adapter. Although unmentioned the team likes Texas Instruments for their product reliability and customer service but aside from all that the specification for the device were much better than all the other Wi-Fi adapters and it was cheaper. It was decided by the team that the Tiny UART was too large for our design. The amount of dedicated space this one component would need was too big, and it was decided to find a new solution on the market for our design. The next device tested was the Wi-Fi Shield Wishield v2. This component was not what the team wanted. The Wi-Fi Shield ran off Arduino and had a high voltage requirement of 5 volts. The next component tested was the Olimex Wi-Fi Adapter. This component has an extremely low temperature range of 70 degrees Celsius. The team felt that even with it under the collar, in the hot sun of Florida it could easily exceed this maximum requirements. Overall the team concluded that the project would use the TI CC3100 because of its low voltage, high performance and low price. After testing that using the component there are no regrets by the team for selecting this device.

Bluefruit EZ-Link (Courtesy of Adafruit)

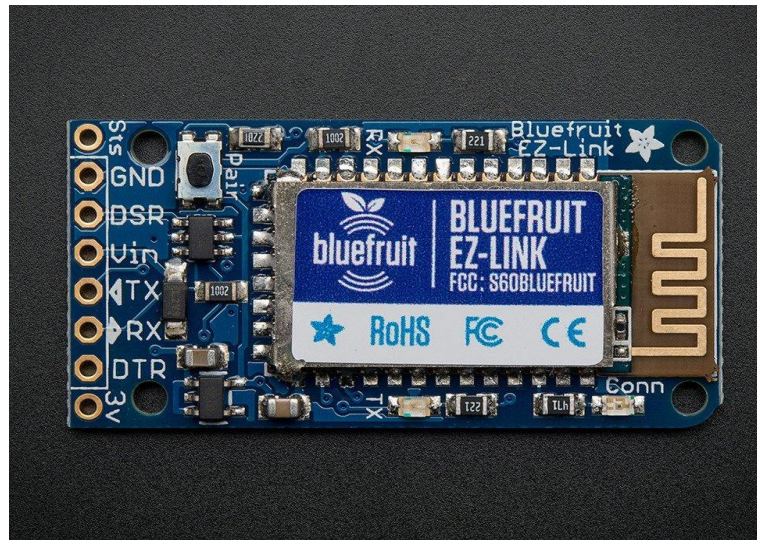

For the final project we chose to use the Bluetooth EZ-Link because of its availability and ease of use. It was found to be easy to code and it interacted with our microcontroller very reliably. It came with its own built in antenna with is considered uncommon. This device allowed us to easily upload our code. In addition because this product is used to monitor an animal which its owners are not home it worked perfectly because of the range.

3.2.5.1 Internet of Things

ThingSpeak.com is a website built around the Internet of Things. ThingSpeak.com uses channels to send and store this data. Once a ThingSpeak channel is created, data can be sent to the channel, ThingSpeak.com can manipulate the data, and ThingSpeak.com can send the data. The website works with mobile applications and web applications as well as Twitter, Arduino and Raspberry PI among others. Its features include:

1. Real-time data collection and storage
2. MATLAB analytics and visualizations
3. Alerts
4. Scheduling
5. Device communication
6. Open API
7. Geolocation data
8. Available on GitHub
9. ThingSpeak channel
 - a. Eight fields that can hold any type of data.
 - b. Three location fields.

- c. One status field.

Freeboard.io is a cloud based website that can be used with the Internet of Things platform that helps display data in real-time. The idea behind the website is to create easy to use dashboards that can display device and sensor information that has been uploaded to the cloud using Wi-Fi or other networking technology. Freeboard.io features include:

1. Flexible Data Sources
 - a. Seamless integration with dweet.io, or access any web-based API.
2. Develop with Widgets
 - a. Select from a growing list of included widgets, or add your own.
3. Drag & Drop Simplicity
 - a. Design layouts that exactly meet your needs. Change them quickly and easily as requirements change.
4. Public or Private access
 - a. Keep your Freeboards public and pay \$0. Select one of our low cost plans to make them private.
5. Clone it
 - a. Duplicate any Freeboard and use it as a starting point for a new one (permission required).
6. Share Instantly
 - a. Every Freeboard has a unique URL that you can share via email, SMS, and social networks.

Dweet.io is a cloud-based website that can be used with the Internet of Things platform that is similar to twitter. This website does not need to be setup, data only needs to be sent to dweet.io to be published automatically in the cloud. Dweet.io is a web API and can easily be implemented into microcontroller code with just a couple lines of code. Dweet.io features:

1. Dweeting
 - a. Send data from your thing to the cloud by "dweeting" it.
2. Real-time Streams
 - a. Create real-time subscriptions to dweets.
3. Alerts
 - a. Notify you when something in the data you dweet falls outside set of conditions.
4. Client Libraries

Wolfram Data Drop is a cloud based website that allows for the accumulation of data from sensors, devices and programs. The website uses the Wolfram Data Framework to make data semantic and make the data computable. Using the Wolfram Language data can be manipulated in multiple ways including data computation, data visualization, data analysis, and data querying among others. Wolfram Data Drop features include:

1. Accumulate Data from Anywhere
 - a. Web API
 - i. Anything that can reach the web can send data.
 - b. Twitter
 - i. Data can be sent to @WolframDataDrop to add short pieces of data.
 - c. Email
 - i. Data can be sent to datadrop@wolframcloud.com.
 - d. Web Form
 - i. Enter data in any format in an embeddable smart web form.
 - e. Wolfram Language
 - i. Add any type of data with a single built-in function.
 - f. Custom API
 - i. Use Wolfram Cloud Instant API to create custom API for data.
 - g. Custom Form or APP
 - i. Use Wolfram Universal Deployment System to create instant forms or apps for adding data.
 - h. Connected Devices and FrameWorks
 - i. Use connectors from Wolfram Connected Devices Project Partners.
2. Instant Access to Powerful Analysis
 - a. Native Time Series Support
 - i. Analyze, visualize, manipulate, forecast, etc. time series using built-in capabilities of the Wolfram Language.
 - b. Built-In Geographic Capability
 - i. Immediately connect your data with maps and deep geographic data from the Wolfram Knowledgebase.
 - c. Built-In Figure Processing
 - i. Use figure processing capabilities of the Wolfram Language.
 - d. Instant Machine Learning
 - i. Use automated machine learning system in the Wolfram Language to analyze data.
 - e. Make Dynamic Reports Automatically
 - i. Create interactive documents based on data.
3. Typical Uses
 - a. Setup Web Dashboards
 - i. Do analyses and create visualizations continuously from Data Drop data.
 - b. Generate Alerts
 - i. Define any criterion to generate email or other alerts from Data Drop data.
 - c. Create A Web Query API
 - i. Make it easy to query data from Data Drop from any web system.
 - d. Generate Automated Reports

- i. Periodically create reports from Data Drop data.
 - e. Aggregate Data From Multiple Sources
 - i. Use Wolfram Data Framework and Wolfram Cloud to combine different data from Data Drop.
 - f. Access Data From Any Language
 - i. Automatically generate code to access Data Drop data from any common computer language.
 - g. Instant Data Publishing
 - i. Make data quickly available through Data Drop.
 - h. Natural Language Data Queries
 - i. Setup a system to answer natural language queries using data from Data Drop.
- 4. Integrated Into All Wolfram Platforms
 - a. Wolfram Alpha
 - i. Get an instant report on data from Data Drop.
 - b. Wolfram Development Platform
 - i. Include data from Data Drop in programs and applications.
 - c. Wolfram Data Science Platform
 - i. Automatically create reports from data from Data Drop.
 - d. Wolfram Programming Lab
 - i. Learn to program with real-time data from Data Drop.
 - e. Wolfram Device Analytics Platform
 - i. Fast path to dashboards and back-end analytics for connected products.
 - f. Wolfram Discovery Platform
 - i. Real-time data from Data Drop for R&D processes.
 - g. Wolfram Mathematica
 - i. Real-world data from Data Drop for technical computing.

The Internet of Things platform is an important part of the Doggy Pal Collar project. Data collected from the sensors on the collar will be sent to the cloud where that data will be manipulated and displayed. This data must be accessible and also a message must be sent to the smartphone of the owner of the collar if any data collected is abnormal for the heart rate monitor. Each Internet of Things website offers advantages and disadvantages, however the requirements and specifications for the Doggy Pal Collar will help determine which website is best used for the project. Based off this criteria, the dweet.io and freeboard.io websites were chosen. While Wolfram Data Drop offers an extensive list of features and programming power, many of those features will not be necessary for the Doggy Pal Collar. In contrast, ThingSpeak.com does not offer enough features to work well with the Doggy Pal Collar. While Wolfram Data Drop is too big and extensive for this project, dweet.io and freeboard.io will do exactly what is necessary for the smart collar. Each website offers features that will help make the Doggy Pal Collar a success.

For the final project, ThingSpeak was chosen for the Internet of Things data display. The code to implement ThingSpeak into the project was easier to work

with and did not take up much space on the microcontroller. ThingSpeak was also able to do what both dweet.io and freeboard.io could do but in one website instead of two. One downside was ThingSpeak has a 15 second update delay, but for the purposes of displaying the data collected from the collar this 15 second delay was not a problem.

3.2.6 Power Supply

When researching battery power supply for this smart collar, 4 important constraints needed to be taken into consideration.

1. Safety
2. Size/weight
3. Rechargeable/non-rechargeable
4. Time duration between recharging and cycle life

The reality is dogs are not conscientious creatures and therefore this battery will have to endure some rough housing. The Doggy Pal Collar is designed to keep dogs safe and help safeguard their health. For these reasons batteries that had harmful chemicals or gave off toxic fumes were disregarded.

Size and weight will be a major issue when it comes to power. This device will be around a dog's neck and worn for 24 hours a day for multiply days. In order to keep the dog from trying to take it off in distress or discomfort the size and, consequently, the weight needs to be small and light. The collar will not be more than a few inches tall with an even smaller depth. This means battery packs, if used, need to be kept to two or three to keep the size down. If the batteries were larger than 3 inches tall when vertical (standing up) and/or horizontal (on their side) they were disregarded. Also if the batteries weighed more than half a pound, whether by themselves or in a pack, then they too were disregarded.

As non-rechargeable batteries are the most common and therefore the most available to the owner, they were taken into consideration and compared to the rechargeable batteries. Non-rechargeable batteries perfect for devices where charging is impractical or impossible. Though there is the possibility that the dog may become lost this smart collar will enable the owner to quickly locate the dog so this smart collar should never be inaccessible to the owner. Also, in order to track and monitor the dog the Doggy Pal Collar needs to be running for long hours; for at least a full 24 hours preferably. Non-rechargeable batteries cannot reach this level of power that would be needed.

For this project, price is a major constraint. In order to keep well within budget every element is compared and weighted to see the long-term cost benefits. So the question is which battery cell type offers more savings. Things that need to be taken into consideration was the cost per life cycle, the cost of a charger, and cost of running that charger. Pete, from www.frequencycast.co.uk, has done a

rough calculation of rechargeable batteries versus non-rechargeable batteries to see which one was a better investment. He points out how rechargeable batteries have a lower mAh than non-rechargeable batteries so to compare them he found “out how many charging cycles will be needed to get the same consumption” as a non-rechargeable battery. His calculations resulted in rechargeable batteries winning over the non-rechargeable. It was later pointed out that after two years rechargeable batteries will suffer from a greater internal discharge that increases with time. When this happens the charge won't last as long for rechargeable. Also, taking the charger itself into consideration, consumers commonly leave rechargeable equipment plugged into their charges long after full charge has been reached. Unless the consumer has the up-to-date chargers with built in timers they could be wasting money and damaging their rechargeable batteries anyway. Looking at all the advantages and disadvantages of both battery cell types revealed the best battery choice for this project; rechargeable batteries. The reasons why are:

- Environmental impact – With the ability to be used over and over multiple times before they need replacing there is a minuscule amount going to landfills. They are also energy efficient because they use less energy recharging than the energy needed to make new batteries.
- Size – They are available in the same sizes and voltages as disposable types, and can be used interchangeably with them.
- Convenience – They, in some cases, can last up to 5x longer, on each charge, than disposable batteries when used in high drain devices.
- Charge Evolving – With battery chargers becoming more convenient, reliable, easy to use and durable recharging batteries has become easy and convenient. Some battery chargers can charge many different types of batteries interchangeably. They charge in a number of different ways as well from USB ports to car-ports.
- Performance: Rechargeable batteries will use a 1.2 V of energy the duration of their use. This means peak performance is constant even at low battery. Some batteries provide a refresh mode to drain the batteries before fully charging them again to get optimal performance and long life.
- Time Saving - Having rechargeable batteries means there's never a time where the consumer will run out of batteries. Some battery charges can even recharge the battery in under an hour.
- Cost Efficiency - Even though the initial cost of rechargeable batteries and a battery charger is extremely costly, it is inexpensive to charge them and they are capable of being used for over more than 500 times.

As mentioned before, the desire duration of time between recharging would last a few days. This means that the battery's amp hour needs to exceed the max current draw needed to run the smart collar enough to last at least a day. Even though the smart collar may not reach or stay at the maximum current it is best have a power overhead so as not to tax the battery and for safety reasons. It is also best to test the current draw on a bench top power supply but for now and

educational guess will do. The current draw for each component is shown in Table 3.2.6-1:

Table 3.2.6-1 Total Current and Voltage

Component	Max Current Draw	Max Voltage
Microcontroller	25 mA	4 V
Heart-rate monitor	.17 mA	3.6 V
Temperature sensor	.27 mA	5.5 V
Wi-Fi	53 mA	3.6 V
GPS	25 mA	4.3 V
Conclusion	Total current draw is 103.44 mA	Cannot exceed a Voltage of 5.5 V

Knowing this information is crucial to choosing the right battery. Since the battery needs to exceed the max current draw in order to safely power the system. For the Doggy Pal Collar to have a battery supply for a full day the battery will need to be a 5.5V or lower with a current power of 25000 mA/h or added in parallel. Once the decision for rechargeable batteries and the current and voltage needed was found the process of choosing which battery chemistry to use began. The batteries were looked at for their durability, voltage and current power, overall size, and cost efficiency. Knowing that the size may vary depending on how many are needed in a pack was taken into consideration but the signal ones that were far too large were immediately disregarded. Important information from the research of all the different battery chemistry types is shown in Table 3.2.6-2 and Table 3.2.6 - 3 for easy comparing and contrasting:

Table 3.2.6-2 Compare/Contrast

Features	Lithium-Ion (Li-Ion)	Lithium-Ion Polymer (Li-Poly)	Alkaline	Nickel Cadmium (Ni-Cad)	Nickel Metal Hydride (Ni-MH)
Nominal Cell Voltage	3.2V – 3.7V	3.3 V-3.7 V	1.5 V	1.2V	1.20V
Energy Density (Wh/kg)	110 - 160	100-130	80	45-80	60-120
Specific Power (W/kg)	~250 - ~340	10000	0	250 - 1000	250 - 1000
Self-discharge rate (per month)	8% at 21°C 15% at 40 °C 31% at 60 °C	2% – 5%	<0.3% per	15%–20% per	13.9–70.6% 36.4–97.8% at 45 °C Low self-discharge: 1.3–2.9% at 20 °C
Charge Time (hours)	2-4	2-4	2-3	1	2-4
Overcharge Tolerance	Very Low	Low	Moderate	Moderate	Low
Cycle Times	400-1200	1000	20 after deep discharged	500	500
Shelf life	>20-year shelf life	>20-year shelf life	7 - 10 years	5 years	5 years

Table 3.2.6 - 3 Compare/Contrast Continued:

Features	Lithium-Ion (Li-Ion)	Lithium-Ion Polymer (Li-Poly)	Alkaline	Nickel Cadmium (Ni-Cad)	Nickel Metal Hydride (Ni-MH)
Maintenance Requirement	Not required	Not required	Not required	30 to 60 days	30 to 60 days
Durability	Hard Casing Can explode if damaged	Soft Casing Can explode if damaged	Hard Casing Won't explode is damaged	Hard Casing Won't explode is damaged	Hard Casing Won't explode is damaged
Operating Temperature (Fahrenheit)	-4° to 140°	32° to 140°	32° to 149°	-40° to 140°	-4° to 140°
Size	Very small - Small Compact	Very small - Small Compact	Small - Medium Not compact	Small - Medium Not compact	Small - Medium Not compact
Weight	Very light - Light	Very light - Light	Very light - Light	Light	Light
Price (each)	>\$10.00	>\$10.00	\$0.75 - \$1.00	\$1.00 - \$3.00	\$1.00-\$2.00
Cost per Cycle (Not including the cost of electricity and chargers.)	\$0.03	\$0.01	\$0.04	\$0.002	\$0.002

After much time and research the Lithium-Ion Polymer batteries were chosen for this project. Lithium Ion Polymer (Li-Poly) batteries can come in an array of sizes and voltages. Manufacturers can design any size battery, within reason, and have them produced economically; some batteries even resemble the size of a credit card. The gelled electrolytes enable manufacturers to simplify the packaging, in some cases eliminating the metal shell which makes this perfect for small projects. The chosen battery is Adafruit's Li-Poly 3.7V 2500mA battery with comes with a pre-attached 2-pin JST-PH connector that is advertised to "click in and out smoothly to its connecting JST jack" to prevent snagging or getting stuck.

One major drawback for these types of batteries is they're not durable and require extra care during use and charging. This battery also comes with a protection circuitry which keeps the battery's voltage from becoming too high (this can over-charge the battery) or becoming too low (this will over-use the battery). The battery will cut-out when completely dead at 3.0V. This protection will also prevent output shorts. With all the improved safety these batteries are more

resistant to overcharge which means there's a lesser chance for electrolyte leakage.

As stated above, these batteries are not safe and a worrisome feature of Adafruit's Li-Poly batteries is, like most, they do not have a thermistor built in because they are not always next to the battery. It's originally intended to be used at low charge rates and in cool indoor temperatures which makes it extremely important to use a Li-Poly constant-voltage/constant-current charger when recharging; Adafruit suggests charging at 1/2C or even less. When charging these batteries it's important to make sure that the charger voltage is less than or equal to the battery voltage. For the best battery performance/life the battery voltage and charger voltage should match. If these batteries are over-charged they, at the very least, will become permanently damage or, at worst, will cause an explosion and/or fire.

Combining these batteries in series or parallel is also extremely dangerous to DIY. One battery may discharge into another causing damage or a fire. These batteries also come with a long list of what not to do which includes, but not limited to, transporting or storing the battery near metal; strike, crush, or puncture the batteries; leave the batteries in a high temperature environment; use the batteries in a location where there is high static-electricity or magnetic fields, etc. That all being said, this Lithium-Ion Polymer battery will be encased in a 3D printed collar that is known for its durability and will add some much need protection for the battery.

Due to some of the components changing in the Doggy Pal Collar and the desire to provide a long battery life the final battery that was chosen is Adafruit's 3.7V, 4400mAh Lithium-Ion battery. This battery has many of the same features as Adafruit's 3.7V, 2500mAh Lithium-Ion Polymer battery. The Lithium-Ion battery has a slightly larger in size and weight compared to the Lithium-Ion Polymer, but it will allow the Doggy Pal Collar to last for about 3 days. Table 3.2.6-4 shows what the new maximum current draw and maximum voltage of the Doggy Pal Collar will be.

Table 3.2.6-4: Final Maximum Power:

Components	Max Current Draw	Max Voltage
Microcontroller	25mA	4V
Pulse Sensor	.17mA	3.6V
Temperature Sensor	.27mA	5.5V
Bluetooth	40mA	16V

GPS	25mA	4.3V
Accelerometer	11.83mA	3.6V
Total:	Total maximum current draw is 102.27 mA	Cannot exceed a voltage of 3.6 V

3.2.7 Microcontroller:

The design concept of this project includes four sensors which must gather data from their target object and have it transmitted through local wireless internet to a web server. A wireless communication module will be necessary in order to transmit the data gathered by the sensors wirelessly to the web. The collection of sensors and the wireless communication module must be controlled by some component in order to communicate in an orderly manner and have their data all processed properly. Some of the possible controllers that were considered for the project were a computer, a microcontroller, and a Field Programmable Gate Array (FPGA).

Although the sensors gather data in real-time, a real-time response by the controller is not necessary. There are no buttons or switches in the design to necessitate reacting to end-user input. An operating system was decided to be unnecessary as well. The controller simply needs to collect the data from the sensors and pass it off to the wireless communication module. No complex computations or complex digital signal processing will be needed, either. For these reasons, a microcontroller was chosen as the control unit for this project.

TM4C123x: This line of microcontrollers is made by Texas Instruments. It is targeted to strike a balance between floating point performance and high power efficiency. It features the ARM Cortex-M4 CPU with floating point and CPU speeds up to 80 MHz. They have up to 256 KB Flash, 32 KB SRAM, and 2 KB EEPROM. They have two available high speed Analog-to-Digital converters which operate at up to 1 million samples per second with no loss to accuracy. Also available are two CAN 2.0 A/B controllers and USB 2.0 (Host/Device/OTG). The MCU is capable of serial communication with 8 UARTs, 6 I²Cs, and 4 SPI/SSI. Power consumption can be brought as low as 1.6 micro Amps.

The Cortex CPU is stated to simplify digital signal processing and excel at math-heavy operations. The TM4C123x line is supported by TivaWare. Among its listed applications the ones that could be useful for this project are connectivity, sensor aggregation, and data acquisition.

TM4C123x microprocessors are available from \$4.00 to \$8.00 each from Arrow.com, an Orlando based authorized Texas Instruments semiconductor distributor (Texas Instruments, TM4C Microcontrollers, 2).

TM4C129x: The TM4C129x line of microcontrollers is made by Texas Instruments and features integrated Ethernet MAC+PHY and communication peripherals. The MCU has an ARM Cortex-M4 CPU with floating point and is capable of clock speeds up to 120 MHz. It has 1 MB Flash, 256 KB SRAM, and 6 KB EEPROM. The integrated Ethernet is 10/100, which means it transmits at 10 and 100 Mbps. There are four tamper inputs and hardware acceleration for AES, DES, and other encryption methods. This MCU line has two 12-bit Analog-to-Digital converters (ADC) capable of sampling at 2 MSPS. There are two CAN 2.0 A/B controllers, a full speed USB 2.0, and a high speed USB ULPI interface. The serial communication features include eight UARTs, ten I²Cs, four QSPI/SSI, and a 1-wire master interface.

The suggested applications in the Texas Instruments documentation include industrial sensors, security access systems, communications adapters, industrial HMI control panels, and networked residential systems. This microcontroller line seems to be at security and industrial uses and might not be ideal for the smart collar.

TM4C129x microcontrollers are available on arrow.com for approximately \$11.00 to \$20.00 each depending on the model.

Various development kits and booster packs are available from Texas Instruments for the TM4C12xx line. Features of these kits include OLED and LCD displays, microSD card slots, direct contact and Infrared temperature sensors, multiple axis motion tracking sensors, pressure sensors, and ambient light sensors(Texas Instruments, TM4C Microcontrollers, 3-4).

MSP430F5529: The MSP430F5529 is a 16-bit MCU with a RISC CPU and clock speeds up to 25 MHz. It has 128 KB flash and 8 KB RAM. It features integrated PHY and USB 2.0 and four 16-bit timers which each have from three to seven capture/compare registers. The MCU has three-channel direct memory access, 63 input/output pins, a hardware multiplier which supports 32-bit operations, and a real-time clock. There is a single 12-bit ADC which has internal reference, autoscan, and sample-and-hold capabilities.

The MSP430F5529 also has two USCIs (universal serial communication interface). USCI_A0 and USCI_A1 support automatic Baud-rate detection via UART and synchronous SPI as well as an IrDA encoder and decoder. USCI_B0 and USCI_B1 support synchronous SPI and I2C. The supply voltage can go from 3.6 V to as low as 1.8 V via USB. There is also an integrated USB-PLL and the USB has eight input and eight output endpoints (Texas Instruments, MSP430F5529).

The MSP430F5529 is available on arrow.com for around \$5.00 to \$7.00.

MSP430G2553: The MSP430G2553 microcontroller from Texas Instruments features a 16-bit RISC CPU with 16-bit registers. This MCU boasts ultra-low power consumption with five power saving modes and a supply voltage as low as 1.8 V. It features two 6-bit timers with three capture/compare registers each. There are up to 24 input/output pins which are capacitive-touch enabled. This microcontroller features on-chip emulation with a spy-bi-wire interface.

The USCI features an enhanced UART with automatic Baud-rate detection, an IrDA encoder/decoder, I²C, and synchronous SPI. There is an onboard comparator for analog signal comparison or analog-to-digital conversion. There is also a 10-bit ADC with internal reference, sample-and-hold capability, and autoscan. The ADC is operated at 200 kSPS (Texas Instruments, MSP430G2553).

The MSP430G2553 is available in a 20 pin, 28 pin, or 32 pin package. The MCU is available on arrow.com for approximately \$1.50 to \$4.00 each.

BeagleBone Black Development Board: The BeagleBone Black is an open-source platform and features a Sitara ARM Cortex-A8 processor running at 1 GHz. This microcontroller supports multiple distributions of Linux and Android. The BeagleBone has 512 MB DDR memory and 4 GB eMMC memory. It has 10/100 Ethernet, 5V power via USB, and optional JTAG.

The development environment for the BeagleBone is a terminal interface in the browser. It can run Python, Ruby, INO Sketches, and JavaScript (Texas Instruments, Beaglebone Black Development Board). The BeagleBone Black is available for \$55.00 on adafruit.com.

TM4C123GH6PM: The TM4C123GH6PM is a Texas Instruments TIVA series microcontroller. It features an ARM Cortex-M4F processor that operates at speeds up to 80 MHz using a Thumb-2 mixed 16/32 bit instruction set. It has 256 KB of Flash memory and 32 KB of SRAM. The microcontroller has eight UARTs and four I²C modules.

The UARTs on the TM4C123GH6PM feature a programmable baud-rate generator and separate transmit and receive FIFOs with programmable length, bits for start, stop, and parity. The serial interface characteristics are fully programmable for 5 to 8 data bits with fully selectable parity bit generation and detection and a 1 or 2 bit stop bit.

The IrDA serial-IR encoder/decoder on the UARTs has a serial infrared input/output in addition to the UART input/output. The serial infrared encoder/decoder functions are supported up to a data rate of 115.2 Kbps half-duplex. There is also a programmable internal clock generator which allows the

reference clock to be divided by anywhere from 1 to 256 (Texas Instruments, Tiva TM4C123GH6PM Microcontroller Datasheet).

The TM4C123GH6PM is available on arrow.com for approximately \$7.00.

C2000 Piccolo: The C2000 Piccolo is a microcontroller made by Texas Instruments. The Piccolo features a 32-bit C28x DSP core and a CLA coprocessor which together can handle 240 million instructions per second. The Piccolo also features a Trigonometric math accelerator and can execute common trigonometry math functions in 1-2 cycles.

Tasks can be offloaded to the CLA coprocessor to free up bandwidth in the C28x core. The CLA has access to control and analog peripherals. It can run motors, perform power factor correction, power line communication, LED lighting, and more.

The Piccolo has pulse width modulation shadowing and supports many switching topologies. There are three 12-bit ADCs. There is available motor control software on the chip. The Piccolo also features a FAST software sensor which can replace mechanical sensors. There is an instaSPIN position and speed control suite for motor control.

In the connectivity department, the Piccolo MCU has four UARTs, two I²Cs, three SPIs, two CAN 2.0Bs, and USB 2.0 MAC & PHY (Texas Instruments, C2000 Real-Time Microcontrollers, 4).

The C2000 Piccolo has many features for motors and motor control which are not necessary for the smart collar. The Piccolo was unavailable on arrow.com, adafruit.com, and mouser.com at the time of writing.

C2000 Delfino: The C2000 Delfino is a microcontroller made by Texas Instruments that is targeted at heavy signal processing uses. Like the C2000 Piccolo, it features a 32-bit C28x DSP core with a CLA coprocessor. It has up to 1 MB flash and up to 204 KB SRAM. The Flash-based Delfino features either a dual or single 32-bit floating point C28x core running at 200 MHz. The RAM-based Delfino C28x core can reach clock speeds of 300 MHz.

The Delfino microcontroller features an IQMath virtual floating-point engine to simplify the porting of code between floating-point and fixed-point devices. This microcontroller also features the Trigonometric Math Unit that is found in the C2000 Piccolo. It also features a Viterbi Complex Unit accelerator which is used for vibrational analysis of motors and provides processor acceleration for narrowband PLC standards.

There are four 16-bit ADCs which run at 1 MSPS. The Delfino also has a 12-bit, 12.5 MSPS ADC. It features two I²Cs, three SPIs, four UARTs, USB 2.0 MAC

and PHY, and two CAN 2.0s. It also has two 10 MHz oscillators and a temperature sensor (Texas Instruments, C2000 Microcontrollers, 6).

The C2000 Delfino is available on arrow.com for \$24.36.

C2000 F28M3x: The C2000 F28M3x microcontroller have both an ARM Cortex-M3 core and the C28x core from the other C2000 MCUs. The F28M3x is divided into a Control subsystem and a Host subsystem.

The Control subsystem uses the C28x 32-bit CPU operating at speeds up to 150 MHz. It has from 256 to 512 KB Flash memory, 20 KB ECC RAM, 16 KB parity RAM, and 64 KB ROM. It has six channel direct memory access, one UART and a McBSP/SPI/I2S.

The Host subsystem is powered by the ARM Cortex-M3, a 32-bit CPU operating at speeds up to 100 MHz. It has from 256 to 512 KB flash memory, 16 KB ECC RAM, 16 KB parity RAM, 64 KB ROM, and an external memory interface. It features 32 channel direct memory access, four timers, and two watchdogs. It has 10/100 Ethernet, USB, four SSIs, 5 UARTs, two I²Cs, and two CANs.

The two subsystems share an analog temperature sensor, two analog comparators, and a 10 MHz / 30 kHz internal oscillator (Texas Instruments, C2000 Real-Time Microcontrollers, 8).

The C2000 F28M3x has a listed starting price of \$9.40 according to its brochure.

MSP430FG4618: The MSP430FG4618 has a 16-bit RISC architecture and boasts ultra-low power consumption, consuming 400 microAmps at a speed of 1 MHz in active mode, and 1.3 microAmps in standby mode. It can take a supply voltage as low as 1.8 V and it has five power saving modes. It has 116 KB of flash and 8 KB of RAM.

The MSP430FG4618 also features a 12-bit ADC with internal reference and sample-and-hold as well as autoscan. In addition to the ADC, it has two 12-bit Digital-to-Analog converters (DACs). It has three Op-Amps, a comparator on-chip, and two timers, both 16-bit. Timer_A has three capture/compare registers. Timer_B has seven capture/compare registers. The MCU also has three channel direct memory access.

The MSP430FG4618 features a USCI which has an enhanced UART, IrDA encoder/decoder, synchronous SPI, and I2C. There is also an integrated LCD driver and a real time clock, and the MCU has 80 input/output pins (Texas Instruments, MSP430FG4618).

The MSP430FG4618 is available on arrow.com for \$12.40.

MSP430F2013: The MSP430F2013 is a low-power MCU with a 16-bit RISC architecture which can take a supply voltage as low as 1.8 V. It consumes 220 micro Amps in active mode and 0.5 microAmps in standby and has five power saving modes. It has 2 KB flash memory and 128 B RAM. It has ten input/output pins and is available in a 14-pin or 16-pin package. It can achieve internal clock frequencies up to 16 MHz and also features a 32 kHz crystal oscillator for precision, as well as a low-power oscillator and can take an external digital clock source.

The MSP430F2013 has a 16-bit Timer_A which has two capture/compare registers. It has an on-chip comparator and a 10-bit ADC with internal reference, sample-and-hold, and autoscan. The 10-bit ADC operates at 200 kSPS. There is also a 16-bit Sigma-Delta ADC with differential inputs.

The MSP430F2013 has a Universal Serial Interface (USI) which supports SPI and I²C communication. It has serial onboard programming and on-chip emulation with a Spy-Bi-Wire interface (Texas Instruments, MSP430F2013).

The MSP430F2013 is available on arrow.com for \$1.73.

MSP430C092: The MSP430C092 is an ultra-low power microcontroller which can take a supply voltage of 0.9 V operating at 1 MHz or 1.5 V operating at 4MHz. It has a 16-bit RISC architecture with extended instructions, 2 KB ROM, 128 Bytes of RAM, and 96 Bytes of lockable CRAM. It has a 1 MHz internal high-frequency clock and a 20 kHz internal low-frequency clock as well as external clock input and a 32-bit watchdog timer.

The MSP430C092 features two 16-bit timers with three capture/compare registers each. It has an ultra-low voltage analog pool with modes for 8-bit ADC, 8-bit DAC, programmable comparator, supply voltage monitor, temperature sensor, and internal reference voltage source. In addition, it has a bootstrap loader and a four-wire JTAG debug interface (Texas Instruments, MSP430C092).

This microcontroller appears to be unavailable from Texas Instruments at the time of writing.

MSP430F5131: The MSP430F5131 microcontroller has a 16-bit RISC architecture with extended memory and a 40 nanosecond instruction cycle. It is capable of taking a supply voltage from 3.6 V to 1.8 V. It features a frequency-locked-loop (FLL) for stability, a VLO, a 25 MHz high-frequency crystal oscillator, and a 32 kHz low-frequency crystal oscillator. It features three channel direct memory access.

This MCU has a hardware multiplier supporting up to 32-bit operations. It also contains up to twelve input/outputs which can tolerate up to 5 V. It has two 16-bit timers which have three capture/compare registers and support high-resolution. It also has a third 16-bit timer with three capture/compare registers which does not.

The MSP430F5131 has two USCI. USCI_A0 supports UART with automatic Baud-rate detection, IrDA encoding/decoding, and synchronous SPI. USCI_B0 supports I2C and synchronous SPI. This MCU also has a 10-bit ADC with internal reference, sample-and-hold capability, and autoscan, which can operate at 200 kSPS and includes a temperature sensor. In addition, there is a 16-channel comparator with an ultra-low-power mode (Texas Instruments, MSP430F5131).

The MSP430F5131 features serial onboard programming and is available in a 38-pin or 40-pin package. It can be found on arrow.com for \$1.88.

TMS470MF03107: The TMS470MF03107 microcontroller has a 32-bit ARM Cortex-M3 RISC CPU operating at up to 80 MHz with a Thumb2 instruction set. It comes with up to 448 kB program flash and an additional 64 kB flash for program space or EEPROM emulation, as well as up to 24 kB SRAM. It has a built-in debug mode, a memory protection unit, and open architecture.

The key peripherals listed on the Texas Instruments site for this MCU are a high-end timer, 16-channel 10-bit multi-buffered ADC (MibADC), two CANs, and two multi-buffered SPIs (MibSPI). In addition, this MCU has two UARTs with local interconnect network interfaces (LIN). It has a digital watchdog timer, and a real-time interrupt timer with vectored interrupts. It has four dedicated I/O pins and 45 peripheral I/Os (Texas Instruments, TMS470MF03107).

The TMS470MF03107 is available from mouser.com for \$11.42.

CC1110-CC1111: The CC110-CC111 is a microcontroller that is designed for wireless applications. It features an 8051 microcontroller core with 8/16/32 kB programmable flash and 1, 2, 4 kB RAM. It has a 128-bit AES security coprocessor for data encryption.

The MCU features seven 12-bit ADCs with up to eight inputs each. It has an I2S interface and two USARTs. The MCU features a 16-bit timer with DSM mode and three additional 8-bit timers, as well as direct memory access and hardware debug support. It can use a supply voltage from 2.0 V to 3.6 V.

The radio is an RF transceiver based on the CC1101. It has a high sensitivity and a programmable data rate reaching up to 500 kBaud. The output power is also programmable up to 10 dBm for all frequencies that it supports. The frequency ranges are 300 to 348 MHz, 391-464 MHz, and 782-928 MHz. It also has digital RSSI / LQI support (Texas Instruments, CC1110-CC1111).

Wireless development kits and software libraries as well as RF calculation tools are available on the CC1110-CC111 section of the Texas Instruments website. The chip and evaluation board are available for \$114 on arrow.com.

CC430F5125: The CC430F5125 is a microcontroller from Texas Instruments featuring an integrated RF transceiver. It has the same 16-bit RISC processor that is found in the MSP430, with extended memory and a system clock up to 20 MHz. It is capable of taking a supply voltage from 3.6 V to 1.8 V. This MCU has three channel direct memory access.

It features two 16-bit timers, one with five capture/compare registers, and one with three. It also features a real-time clock, an integrated LCD driver, and a 128-bit AES encryption coprocessor. This microcontroller has two USCIs. USCI_A0 supports UART, IrDA, and SPI, while USCI_B0 supports I²C and SPI. There is a 10-bit ADC which has internal reference, sample-and-hold, and autoscan. There is also a comparator, a 32-bit hardware multiplier, and an embedded emulation module. The CC430F5125 features serial onboard programming.

The RF Transceiver core can take a supply voltage from 2.0 V to 3.6 V. It operates on frequency bands 300 MHz to 348 MHz, 389 MHz to 464 MHz, and 779 MHz to 928 MHz. The data rate is programmable and can go from 0.6 kBaud to 500 kBaud. The transceiver output power is programmable and can reach up to +12 dBm for all its available frequencies. There's also support for backwards compatibility with an asynchronous serial receive/transmit mode (Texas Instruments, CC430F515).

The CC430F515 microcontroller was unavailable for purchase in small batches at the time of writing. Large batches were unavailable for immediate purchase and had a twelve to eighteen week factory lead time on multiple sites including mouser.com and avnet.com.

RF430FRL154H: The RF430FRL154H is made by Texas Instruments. It is a sensor transponder with a 16-bit MSP430 microcontroller. The MSP430 features 2 KB of FRAM, 4 KB of SRAM, and 8 KB of ROM. It can take a supply voltage from 1.45 V to 1.65 V. It is based on a 16-bit RISC architecture and the CPU can operate up to 2 MHz.

The microcontroller features a 4 MHz high-frequency clock, a 256 kHz low-frequency clock, and an external clock input. There is one 16-bit timer with three capture/compare registers and a 32-bit watchdog timer. The MCU has an eUSCI_B module which supports three-wire and four-wire SPI and I²C. It also features a four wire JTAG debug interface.

The transponder chip allows parameter setting, configuration, and communication through its RFID, SPI, or I²C. There is an internal temperature sensor and a 14-bit sigma-delta ADC. More digital sensors may be connected through its SPI or I²C communication modules (Texas Instruments, RF430FRL154H).

The RF430FRL154H is available for \$5.49 on mouser.com.

3.2.7.1 CAN 2.0

CAN (Controller Area Network) is a serial communication protocol which is a method of standardization of assigning identifiers to communication functions. There are two message formats; standard and extended. The standard format is 11 identifier bits and is the original address format. The extended format is introduced by CAN 2.0 and uses 29 identifier bits. A 1 bit identifier is used to distinguish between standard and extended formats. The standard format is backwards compatible with implementations that came out before CAN 2.0.

According to the CAN 2.0 specification, CAN has:

- Prioritization of messages
- Guarantee of latency times
- Configuration flexibility
- Multicast reception with time synchronization
- System wide data consistency
- Multimaster
- Error detection and signaling
- Automatic retransmission of corrupted messages as soon as the bus is idle again
- Distinction between temporary errors and permanent failures of nodes and autonomous switching off of defect nodes

(Bosch, CAN Specification Version 2.0, 5)

The bitrate is fixed among a system. The bus is a single channel, and when the bus is not in use any connected peripheral may transmit a message. If multiple units attempt to access the bus, the unit with highest priority gets access. The number of units that may be connected does not have a hard limit, but will be limited by electrical loads and delay times. CAN 2.0 A uses the older CAN specification 1.2, while CAN 2.0 B uses the standard and extended formats. Any module that is consistent with CAN specification 2.0 is compatible with A and B (Bosch, CAN Specification Version 2.0).

3.2.7.2 I²C

I²C (Inter-Integrated Circuit) is a communications protocol for an embedded system in which one or more slave devices connect to one or more master devices (usually the microcontroller) in series using only two wires; Serial Clock (SCL) and Serial Data (SDA). The protocol is capable of supporting multiple master units, but for this project the microcontroller will be the only master. In the I²C protocol each slave has its own distinct address, and the protocol is theoretically capable of supporting an unlimited number of connected devices. I²C is a simple communication method that is usable even with slow microcontrollers and only requires two I/O pins. There are various modes of clock

frequency used for the I²C communication line; 100 kHz, a 500 kHz Fast mode, a High Speed mode which can reach up to 3.4 MHz, and an ultra-fast mode which can reach 5 MHz. The clock is generated by the master unit and one bit of data can be transferred with each clock pulse. When the data line is not in use, it is pulled to 'high' by pull up resistors. To use the line, a module pulls it low to create a zero, and releases it to create a one. When the master begins a command it transmits a START bit pattern and finishes with a STOP pattern. Data is transmitted on the I²C in bytes. After each byte there must be an acknowledge bit. The acknowledge (ACK) bit comes from a slave, and allows it to communicate that it is ready to accept more data. If the slave unit needs the master to resend or it needs more time, it can send a not-acknowledge (NACK) instead (I²C Info, I²C Info – I²C Bus, Interface and Protocol). A representation of data transfer via I²C can be seen in figure I2C1.

For this project to use the I²C communication method, the microcontroller would be the master unit, while the heartbeat monitor, temperature sensor, accelerometer / GPS, and wireless communication module would each be slaves. There would need to be pull up resistors on both the SCL and SDA lines between each one or two modules. Assuming the accelerometer / GPS to be on the same integrated chip, and each other slave module to be on its own integrated chip, there would be four slave modules connected to the microcontroller. Thus approximately four pull up resistors would be needed on the two wires. Since it is not crucial to have an extremely fast sampling rate from the sensors that will be connected in this design, the relatively slow nature of serial communication (in comparison to parallel) is of little concern. The addresses of slave modules can either be fully or partially pre-set by the manufacturer. Those which are only partially pre-set have adjustable addresses to avoid conflicts, since all slaves on the I²C must have different addresses. When the other modules are chosen for this project, attention will have to be paid to ensure the avoidance of such address conflicts, if the I²C communication method is used. Most microcontrollers have I²C modules and I²C would be a good choice for the communication method between the modules for this project.

Figure 3.2.7.2-1: Data transfer on I²C (Courtesy of Texas Instruments)

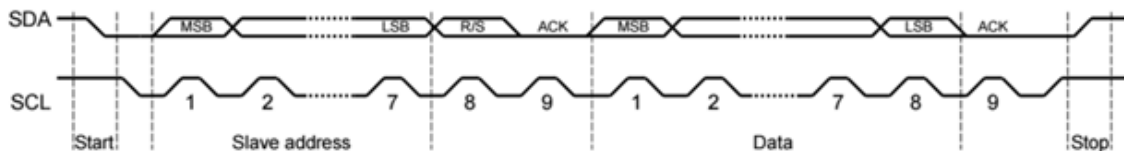

3.2.7.3 UART

The UART (Universal Asynchronous Receiver/Transmitter) converts serial data received from a peripheral device to parallel for the CPU, and converts parallel data in the form of bytes from the CPU to serial data in the form of bits for peripheral devices. A functional block diagram of a UART can be seen in figure

U1 below. UART modules take an input clock with a programmed frequency and divides it to produce a baud clock. The baud clock is either sixteen- or thirteen-times the baud rate of the UART, meaning each bit that is transmitted or received lasts for thirteen or sixteen cycles of the baud clock. The divisor for the baud clock can be configured manually by writing to a register. UARTs have adjustable data width, and all transmissions have one start bit, 5-to-8 data bits, optional parity bit, and then a stop bit (Texas Instruments, Keystone Architecture Universal Asynchronous Receiver/Transmitter (UART) User Guide).

An excellent summary of the functions of the UART according to Ken Conway and Michael DeHaan of TechTarget.com is:

“(The UART)

- Converts the bytes it receives from the computer along parallel circuits into a single serial bit stream for outbound transmission
- On inbound transmission, converts the serial bit stream into the bytes that the computer handles
- Adds a parity bit (if it’s been selected) on outbound transmissions and checks the parity of incoming bytes (if selected) and discards the parity bit
- Adds start and stop delineators on outbound and strips them from inbound transmissions
- Handles interrupts from the keyboard and mouse (which are serial devices with special ports)
- May handle other kinds of interrupt and device management that require coordinating the computer’s speed of operation with device speeds”

(TechTarget, UART (Universal Asynchronous Receiver/Transmitter))

The microcontroller for this project has multiple UART modules and is capable of interfacing with multiple sensors simultaneously using them, thus making UART seem like a good candidate for the communication protocol in the smart collar’s system. However, the TMP007 temperature sensor that will be used can only interface using the I²C protocol. For this reason, and for the sake of simplicity, the entire design will use the I²C communication protocol wherever possible. Figure 3.2.7.3 - 1 shows the block diagram of the UART.

Figure 3.2.7.3-1: Block Diagram of the UART (Courtesy of Texas Instruments)

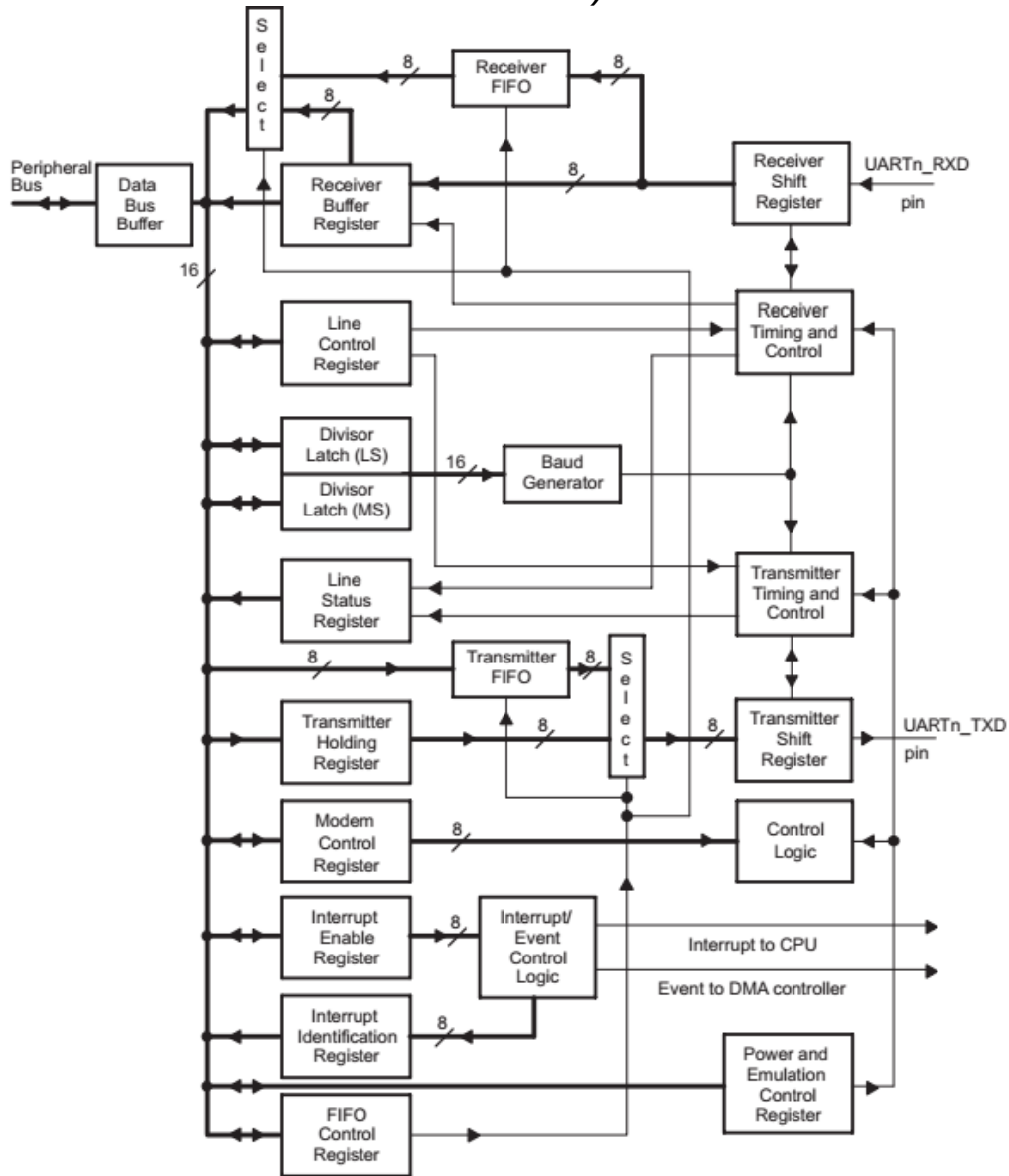

For the final project, the Atmega328p chip was chosen. The Arduino Uno was the microcontroller used for the testing and prototyping of the Doggy Pal Collar, therefore it was natural to stay with the Atmega328p for the final design. This chip was low-powered and easy program. It also had more than enough pins for the project and was able to handle the different components of the Doggy Pal Collar without running into any delays or errors.

3.3 Microcontroller Programming

3.3.1 Code Composer Studio

Code composer studio is an integrated development environment (IDE) for Texas Instruments embedded development. In addition to the IDE itself, Code Composer Studio has an App Center which can provide additional useful development software for a large variety of design tasks. There are packages available for the assorted product lines of different Texas Instruments microcontrollers, such as the C2000 control SUITE, MSP430Ware, and Tivaware. Tivaware is the package focused on the Cortex ARM microcontrollers, and will undoubtedly prove useful in the embedded software development necessary for this project. There are also tools available for Linux and a GUI Composer. This project will be coded on a machine running the Windows operating system, however the GUI Composer may be of interest in later stages, when presenting the information gathered from the sensor suite on the collar is to be aggregated and presented to the end-user for viewing. As an additional useful feature, if a particular embedded device platform is selected during the installation of Code Composer Studio, the App Center will filter out software packages that are not relevant to the selected device platform. Once a software package is chosen and installed, the user can use the Resource Explorer feature to explore sample code and documentation to find and begin immediately using the desired relevant material.

The Code Composer Studio IDE has a C compiler which has been specifically optimized by Texas Instruments for each embedded device platform. The IDE has the ability to provide advice to the user on the code being compiled in order to optimize for device performance, application code size and memory efficiency, and power efficiency. For this project, the size of the code will most likely be small enough that optimization in that regard will not be necessary. The performance of the embedded processor will be of some importance due to having multiple sensors sampling simultaneously and all of their data being processed by the microcontroller and then being communicated wirelessly. Power efficiency is of some concern due to the fact that this device will be portable, and the ability to go for long periods of time without recharging will be beneficial and highly desirable. According to the documentation, devices which have an ARM Cortex-M core for the most part feature an Instrumentation Trace Module (ITM). The ITM module, according to the documentation provided by Texas Instruments, “provides a high-level software view of what is happening on the device. ITM enables features such as: Statistical profiling, variable tracing and interrupt profiling” (Texas instruments, Code Composer Studio v6).

TI-RTOS (Texas Instruments Real Time Operating System) is a scalable operating system available in CCS which provides device drivers, system software, and pre-integrated software components. TI-RTOS can be installed

through the CCS App Center. There are different versions of TI-RTOS available for the different lines of embedded devices, and there is one specifically for the TivaC line called TI-RTOS for TivaC. TI-RTOS can also be used outside of Code Composer Studio. TI-RTOS has source files, pre-compiled library, and example code. From the TI-RTOS User's Guide:

“(TI-RTOS Network Services)

- **TI-RTOS Kernel – SYS/BIOS.** SYS/BIOS is a scalable real-time kernel. It is designed to be used by applications that require real-time scheduling and synchronization or real-time instrumentation. It provides pre-emptive multi-threading, hardware abstraction, real-time analysis, and configuration tools. SYS/BIOS is designed to minimize memory and CPU requirements on the target.
- **TI-RTOS Instrumentation – UIA.** The Unified Instrumentation Architecture (UIA) provides target content that aids in the creation and gathering of instrumentation data (for example, Log data).
- **TI-RTOS Networking – NDK.** The Network Developer's Kit (NDK) is a platform for development and demonstration of network enabled applications on TI embedded processors.
- **TI-RTOS Interprocessor Communication – IPC.** IPC contains packages that are designed to allow communication between processors in a multi-processor environment and communication to peripherals. This communication includes message passing, streams, and linked lists. These work transparently in both uni-processor and multi-processor configurations.
- **MSPWare, MWare, TivaWare, CC25xxWare, and the CC3200 SDK's driverlib.** These provide software designed to simplify and speed development of applications on the corresponding device family. These components are rebuilt to include only the portions required by TI-RTOS.
- **XDCtools.** This core component provides the underlying tooling for configuring and building TI-RTOS and its components. XDCtools is installed as part of CCS v6.x. If you install TI-RTOS outside CCS, a compatible version of XDCtools is installed automatically. “
(Texas Instruments, TI-RTOS 2.14 User's Guide)

The TI-RTOS Kernel SYS/BIOS real-time kernel might prove to be very useful when developing this project. The sensor suite for the smart collar contains several instruments which will be operating continuously. The UIA is intended to simplify gathering instrument data, which is another feature that could make implementation of the embedded code for the smart collar sensor suite much more convenient. The TivaWare driver library for the TI-RTOS would be useful for the TivaC embedded processor that will be used in this project. Once the device has reached the breadboard prototype stage, testing will be conducted with the TI-RTOS to attempt to determine its level of usefulness in facilitating communication between the embedded processor and all of its connected sensor modules.

3.3.2 LM Flash Programmer

LM Flash Programmer is a piece of software available for download from Texas Instruments. It is a flash programming utility that can be used with Tiva C series microcontrollers. The program has a simple user interface with a dropdown list to choose the microcontroller product line that will be programmed. The interface can be chosen from another dropdown, as well as the port, speed, and clock source. To program the board, a binary file is selected, and a few options can be chosen. These options include erasing the entire flash, erasing only the necessary pages, resetting the microcontroller after programming is complete, and choosing a program address offset. A hardware reset can also be performed. Also available in the Flash Programmer are some basic flash utilities such as the ability to erase a certain address range, upload the entire flash contents or a certain address range to a binary file, and verifying the contents of the flash.

The LM Flash Programmer is a basic flash utility used to program the flash memory of the microcontroller with code that is already written and compiled. The Flash Programmer could be useful for testing software on the microcontroller if multiple versions are written. The Flash Programmer would provide a simple and quick way to jump between different instances of a program, and allow the design to be tested rapidly running different pieces of code.

3.3.3 Tivaware

Tivaware by Texas Instruments is a peripheral driver library used to access the peripherals on the Tiva family of Texas Instruments microcontrollers that are based on the ARM Cortex-M. According to the Tivaware Peripheral Driver Library User's Guide, the design goals of the Tivaware drivers are:

- "They are written entirely in C except where absolutely not possible.
- They demonstrate how to use the peripheral in its common mode of operation.
- They are easy to understand.
- They are reasonably efficient in terms of memory and processor usage.
- They are as self-contained as possible.
- Where possible, computations that can be performed at compile time are done there instead of at run time.
- They can be built with more than one tool chain."

The User's Guide states that many of the drivers can be used without modification for many applications, however in some cases the drivers might need to be altered or added to in order to meet certain needs. For example, some peripherals with very complex abilities cannot be used with the drivers in the Tivaware library, but the existing Tivaware drivers can be modified to work

with such peripherals as an alternative to creating one's own drivers. The drivers can also be used as a reference to a programmer wishing to code for the peripheral. The Tivaware library contains drivers for all Tiva microcontrollers. Tool chains that are supported are:

- “Keil RealView Microcontroller Development Kit
- Mentor Graphics Sourcery CodeBench for ARM EABI
- IAR Embedded Workbench
- Texas Instruments Code Composer Studio
- GNU Compiler Collection (GCC)”

The Tivaware peripheral driver library will definitely prove to be useful when integrating all the peripherals involved in the smart collar project. The microcontroller is a Tiva ARM Cortex-M based MCU, and at least two of the peripherals- the TMP007 Infrared Temperature sensor and the CC3100 Wireless Network Processor- are manufactured by Texas Instruments. The Tivaware peripheral library also supports Code Composer Studio, which is the primary code development environment that will be used for this project. Integrating the Texas Instruments peripherals involved in this design will doubtlessly be greatly simplified by utilizing the Tivaware Peripheral Driver Library, and it will clearly be a very wise choice to include it in the project.

3.3.4 Energia

Energia is an open source C Language IDE platform which was created in order to bring the Wiring and Arduino framework to the Texas Instruments MSP430. Energia is supported on Mac, Windows, and Linux. It uses the mspgcc compiler and it has plug-ins and integrations available for Code Composer Studio. The development environment contains a code editor, message area for code feedback, console for displaying text output, toolbar, and menus. Software written using the IDE are called sketches, with a .ino file extension, and are written in the text editor. The Edit menu features a “Copy for Forum” option which copies the code from the text editor in a format that is suitable for posting to online help forums, and includes syntax and coloring. This feature would prove very useful if difficulties arise during the software programming phase of the design. Energia features an Auto Format tool which automatically indents code, lines up braces, etc. to improve readability. There is also a Serial Port menu which displays all of the serial devices currently connected and refreshes whenever the menu is opened. Since all the modules of the smart collar will be connected serially this menu is an attractive feature. Energia features libraries which can be used in sketches via the Import Library menu. Using this menu inserts #include statements into the sketch and compiles the library with the sketch. Some libraries are included with the Energia installation, and others are available for download. Energia also includes a Serial Monitor which displays serial data being sent from the microcontroller, negating the need for a third-party terminal program in testing (Energia, Energia Development Environment).

Energia appears to be a promising development environment for the embedded software portion of this project. The ability to display serial data without a third party terminal program would simplify development somewhat. Due to the open source nature of the IDE there is a large amount of community support which is a resource that could be tapped if problems occur during software development for the collar. One possible use of Energia in this project would be as a secondary development environment to Code Composer Studio. Using the Texas Instruments libraries and chip-family specific App Center packages from Code Composer Studio in conjunction with the community support and open nature of Energia it might be possible to get the best of both worlds in terms of embedded development.

For the final project, the Arduino IDE was used for programming the microcontroller and different components of the Doggy Pal Collar. It was chosen because of how easy it was to setup and use and the open source libraries, examples and community that came with the IDE helped make programming each component simple.

4.0 Related Standards

Dirt/Sand/Dust: For electronic devices dirt and dust can have anything from little to catastrophic effects on the project. Overheating is always an important issue when dealing with electronics and a built-up of dust acts like an insulated blanket that prevents proper convection cooling. Dust that gets into or blocks the insulating system can cause integrated circuits (ICs) to overheat and become permanently damaged. ICs are also vulnerable across their contacts. Any dust in there can cause electrical shorts which can also be permanently damaging to ICs. In today's market ICs can have hundreds of exposed electrical contacts per inch. Dust can contain conductive material like water, oils, and metallic elements which can then cause signal errors and abrupt part failure.

High/Low Temperatures: Cold - Under very cold conditions electronic device can suffer shut-downs, malfunctions and even permanent component damage can occur. In some cases components may even crack rendering them useless. Batteries are also affected and can have their life-span shorten, reduce their effectiveness and damage their internal elements when exposed to freezing temperatures. Cold weather slows down electric currents in batteries, which accelerates the release of their charge. Cold weather is also dangerous when devices are exposed to extreme temperature changes. For, example, this may occur when a device is brought inside from the cold weather to the warm house causing condensation, which could lead to permanent damage for electronic components.

Heat - Electronic devices will generate heat simply by operating. They need to be designed with this in mind by adding fans or other cooling systems in order to keep the heat levels down. This means when devices are exposed to outside heat sources the temperature can reach and easily surpass the device's limits, leading to shut-downs, malfunctions and/or component damage. Batteries are particularly sensitive to high temperatures. Heat, like cold, can shorten the battery's life-span or in extreme cases melt and warp plastic enclosures and cases. The same stands for electronic components, it has been proven by data that for semiconductor and electronic components the failure rate is hugely do to heat and life shortens.

Weather: Humidity - Any way an electrical device comes in contact with water, like rain storms, humidity, pools, etc., can be devastating. Low humidity can cause damaging static charges, while high humidity can lead to condensation which can then lead to corrosion.

Water: All types of water, regardless of its form, can cause corrosion if not properly dried. Distilled water, or pure water, is water that has all impurities removed and therefore does not conduct electricity, which will not inflict damage should it come into contact with an electronic device. Water that can conduct electricity is pure water that has dissolved ionic compounds within. This type of

water is the most common and can cause permanent damage to electronic devices.

WIFI: IEEE 802.11 – This IEEE standard has had many subsequent amendments since its 1997 release date. These amendments and standard together are the “basis for wireless network products using the Wi-Fi brand”. They are the “set of media access control (MAC) and physical layer (PHY) specifications for implementing wireless local area network (WLAN) computer communication in the 2.4, 3.6, 5, and 60 GHz frequency bands”.

GPS: The U.S Department of Defense (DoD) regulations “prohibit standard consumer GPS receivers from functioning above 60,000 feet and 999 mph (simultaneously). Though for this project neither of these restrictions will be a problem.

5.0 Realistic Design Constraints

When designing the collar several design constraints were taken into consideration. These constraints include economic, environmental, sustainability, manufacturability, ethical, health and safety. When analyzing the design, all parameters are taken into consideration individually.

The realistic constraints were somewhat complicated. The most obvious one was creating a device that is lightweight and easily wearable for the animal. When it was reviewed this is the first parameter of the design that was looked over. It was quickly realized other devices on the market such as “Fitbark” were large and bulky. It was decided to focus on this as our first task. The size of the collar is limited to the internal components that the team put in it.

The second design question that was asked had to ask ourselves is, should the team make a collar or a collar attachment. Some of the devices on the market such as “Fitbark” attach to a collar whereas others such as “Dogtelligent” are stand-alone collars. When analyzing this constraint, the group had to ask ourselves, what is lost by using a stand-alone over an attachment. The group determined that an attachment collar while yes, would be versatile and able to attach to almost any dog collar, would create a lack of structural integrity for the dog. Although a stand-alone collar would be more expensive for the user, it would offer the dog more comfort overall. The group concluded that an attachment collar would create a sag in the dog's neck and would be painful. In the end it was decided to go with a collar that was stand-alone due to it being more structurally intact, in addition the team can control the constraints of the design.

Next the team had to worry about the material construction of the outside of the collar. The collar itself must be waterproof. The material choices the group had were plastic, rubber, metals, and some composite mixtures of materials. As a team it was decided to craft the device out of a mixture of plastic and rubber, the rubber to hide the exposed input ports. The plastic material would most likely be crafted using a 3D Printer.

5.1 Economic and Time Constraints

The current cost of materials for our current design are as follows:

- Temperature Sensor - \$6.40
- MCU - \$11.42
- Wi-Fi Communication - \$14.07
- Accelerometer -\$7.22
- GPS - \$29.95
- Heart Rate Monitor - \$3.53
- Power System - \$14.95

- Total Cost: \$87.54

The primary overall goal was to make the device cheaper than other similar devices on the market. Generally the attachment style collars are cheaper and since we were going for a stand-alone collar an overall goal would be to make the collar cheaper than the other attachment style collars. Here is a list of collars similar to the collar we created along with their price.

- Dogtelligent - \$120 – Dogtellegent.com
- WUF - \$129 – www.getwuf.com
- Petpace – \$149.95 – petpace.com

As you can see from the above prices, all of these collars are above 120 dollars. As a group it was decided that it is possible to construct one for under 75 Dollars.

Economically it was decided to use the parts that fit our projects overall design and while being the cheapest possible. In addition, the smaller we make the design, the cheaper it becomes. It was decided overall to print our entire project on one board. For mass production this would be the most economic and ideal method. By printing the board as a whole the entire project will be subject to less malfunctions. By reducing the electrical production of the project we were able to reduce the amount of possible errors in the system.

For mass production the parts such as the accelerometer, Wi-Fi, microcontroller can be ordered in mass supply and can be considerably cheaper. In the long run they would be printed all together. The assembly for the project would be very easy, the most time consuming part of production would be using a 3d printer to print out each device. 3rd party outer casing production is something we will discuss for long term. A more advanced mold for the outer casing for mass production will be something that will be done.

The potential impact on the economy will be minimal overall. It may force the other competitors of our collar to lower cost, slightly driving prices down. Since the price margin is large as a group it was decided the amount of profit acquired can be large. As a group it was our goal to keep the cost of production under 50 Dollars. Most collars cost around \$120-\$150. The range for profit is large. As a company

Economically the design will be further expanded in productions for large scale use. For example places that have many dogs, it's possible to produce a simpler design where some of the functions are less required and the collar can be used as a GPS locator. The collar could also be prototyped to be used in large scale environments for tracking animals such as elephants in Africa.

There would be little to no maintenance for this device other than cleaning it and changing the battery. The device would be expected to run for at least 5 years. Within the user manual they will be able to learn how to open the device and

change the battery. Overall this device will have minimal maintenance while maintaining a high profit margin.

The amount of time to produce a device is determined by the amount of time it takes for the manufacturer of the board to produce and send the device. The amount of time to develop and test the device is yet to be determined but is expected to take beyond a month for the team of 5. The expectation to time ratio is expected to be high, as in we expect good results over a short period of time. The device should have very few bugs / issues due to the amount of programming required for the project. The other subsystems of the project will be very easy to troubleshoot / determine if they are working properly. The overall time taker is the programming of the microcontroller of the device.

For the final project, the price went well above \$100 dollars and several components changed. However, The Doggy Pal Collar is still a competitive device even around \$180. This is because the device still offers several data tracking methods compared to other similarly priced devices that only offer one or two ways to track data. The Doggy Pal Collar also does not need a monthly subscription.

5.2 Environmental, Social, and Political Constraints

The outside casing that we decided to use for the harness is environmentally friendly as it was produced using a 3D printer. The material used is not harmful to animals in any way. In addition if a dog were to lose the collar in the ocean (which is highly unlikely) it will not prevent any harm to oceanic life. The device itself will not cause any waste of any sort. The battery charging function is 100% environmentally friendly. As a group we concluded this device/project to be 100% environmentally friendly.

Social Constraints - As a team we concluded that it would be unlikely for any organizations to have any problems with our devices. The exception to this would be if our device is used as not intended such as someone using it for tracking and harnessing an animal.

Political Constraints - All of the software within our project is programmed by us, the devices we are using for the project are all sold with the knowledge that the producers will use their hardware for resale in more complex devices. None of the designs used are breaking patent law, as there are several similar devices on the market. The Collar does not violate any US homeland security laws. The collar will be black as it is not gender specific for the dog. I can't see this device in any way useable in a harmful manner against the US or anyone specifically.

5.3 Ethical, Health, and Safety Constraints

Ethical Constraints - The research team concluded there to be no ethical standards being broken as long as the collar itself is not used in a harmful way. Or in other words the collar is being modified by the buyer and it is used to harm the animal. Ethically the initial reason for our collar is to help diagnose any problems the animal may have through diagnostics using the accelerometer, or monitoring the heart rate of the animal. The programming within the collar will be able to detect certain conditions the animal is experiencing via testing of conditional inputs. For example if the dog rolls the accelerometer will detect a spin of the x axis, etc.

There is little worry of safety as the collar uses a low voltage configuration ensuring the animal cannot be shocked in any way. The port to charge the collar is not exposed to make sure that the dog cannot be shocked via charger port. The collar itself is waterproof, exposure to rain will not shock the dog. The mechanism of the collar is a standard strap collar and cannot harm an animal in any way that a common collar could. There are no blinking lights on the collar that could in some way blind the animal. The collar does not produce any noise or vibration that can cause harm to the animal. If any lights are showing on the collar they are to be directed towards the rear of the animal. The collar is adjustable so that it is able to fit on most small to large size dogs. Improper fitting of the collar would not be recommended.

Health Constraints - The collar is made of non-hazardous materials produced from 3D printers. The plastic material used has been tested and confirmed to be nonhazardous to dogs. The device has been confirmed to be waterproof and not somehow leak and shock the dog.

5.3.1 Animal Testing

Due to laws and regulations during this project it was decided to instead test the device on humans and create mechanical representations of dogs. To do this it was decided to attach the collar using a cylinder. We could spin the cylinder to simulate a roll the dog would do. By doing this several times we analyzed the data and use it to predict within our future code with the dog is doing a roll.

Short Term Testing - Within our short term testing the device was simulated and tested to predict rolls, breathing patterns, Heart rate, and other forms of dog states.

For rolls it was predicted that the device would spin on 1 axis, see figure 5.3.1-1. We needed to determine a function within our code to analyze this type of behavior. We had to determine the minimum and maximum time, in addition to the completeness of a turn. It was determined that approximately 270 Degrees can count as a complete spin for a dog for it to count as a roll. To test this function we hooked the device up to a drill and slowly let it spin to simulate the dog slowly spinning.

Figure 5.3.1-1: Roll Test

Roll Test

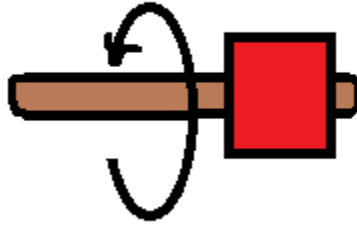

For the device to recognize breathing patterns the accelerometer would experience tight jerks up and down in the Y axis, see figure 5.3.1-2 for our fabricated configuration. These tight jerks could also represent if the animal is throwing up. Taking this information from the accelerometer we were able to determine how hard the animal was breathing. Depending on the rate and magnitude of the jerks the device will process the information and determine which is happening. In addition we have a heart rate monitor built into the device. With both the accelerometer and the heart rate monitor we found we were able to get an accurate reading on the animal. To test this process we simulated the tight jerks by hooking the device up to machines that produce tight vibrations like a bandsaw or car engine. As a car engine runs it produces a similar effect of heart rate or breathing.

To determine and test animal acceleration we simply used the information and software built into the accelerometer. This is one function that most smart dog collars do not have. We simply analyzed the data given off from the accelerometer in the X axis of the device attached to our fabricated configuration as seen in figure 5.3.1-3

Figure 5.3.1-2 Acceleration

Acceleration Test

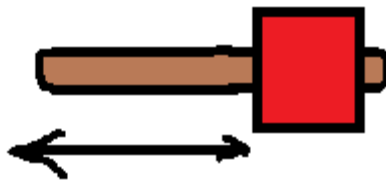

To determine and test the temperature of the animal we are using an open exposed temperature sensor built into the side of the doggy pal collar. By doing this we were able to get a more accurate reading on the animal because the exposed point of the sensor is in direct contact with the animal. There is also a temperature sensor built into the accelerometer if we wanted to get a temperature not exposed to the animal. To test this function we put the exposed

portion of our temperature sensor up to a heated surface and tested the temperature.

To determine and test the distance traveled by the pet it is necessary to set up the GPS monitor for the device. The device reads the amount of distance traveled from the GPS monitor and outputs it for the user. To test this we simply drove around in a car and checked to see if the range was accurate and in sync with our automobile,

The next property to test was the velocity of the collar. It was decided that precise velocity was required for the collar. The decided test to test velocity was to put the collar inside an automobile and travel at a sustained speed for a long period of time. The velocity was measured using the output values of the GPS module. After we tested this we verified it was the same speed as the vehicle traveling.

Figure 5.3.1-3 Velocity Test

Velocity Test

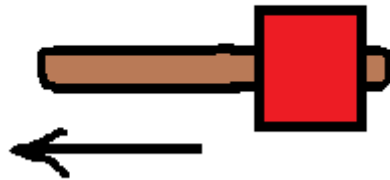
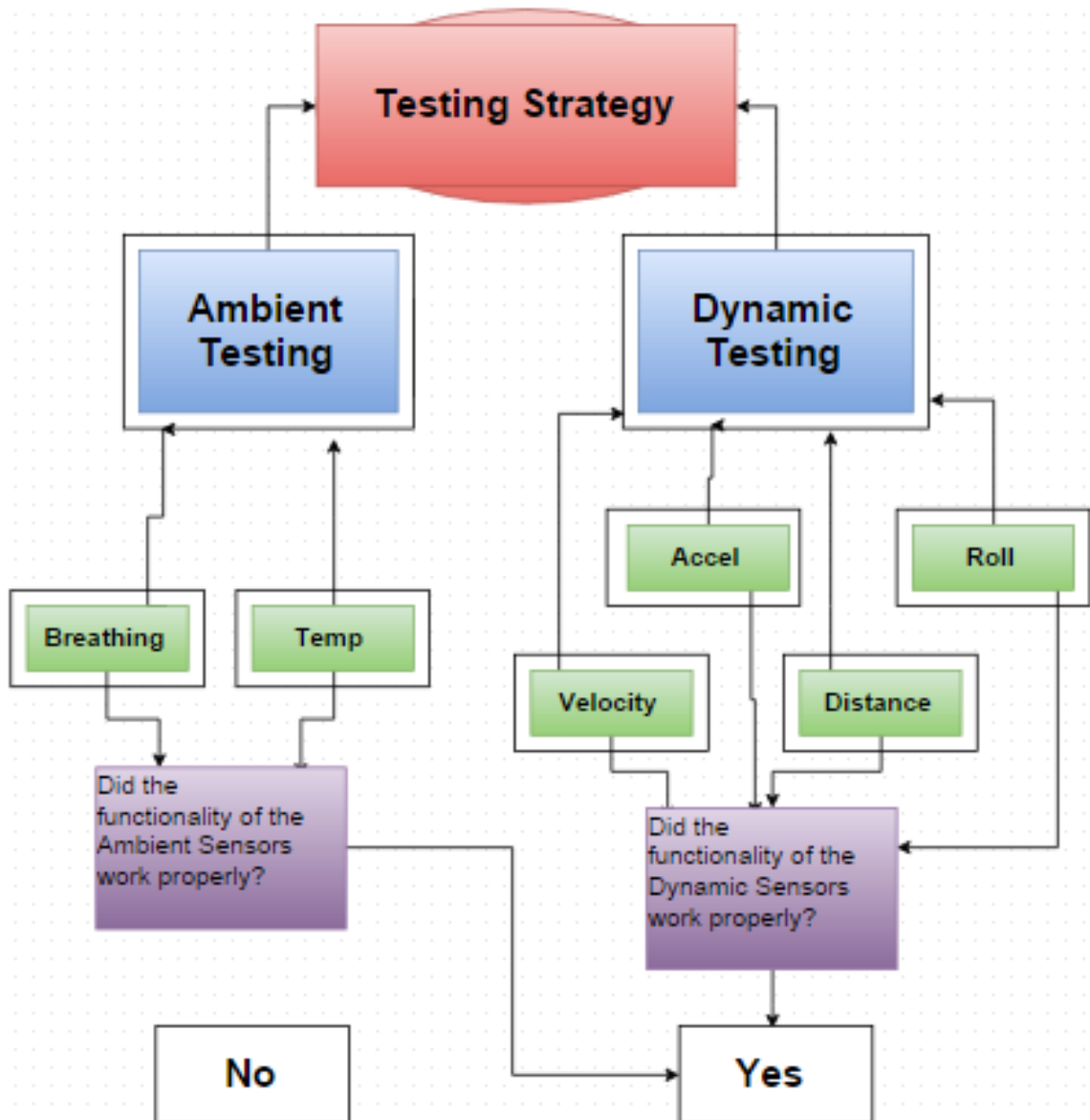

Figure 5.3.1-4: Testing Plan



5.4 Manufacturability and Sustainability Constraints

Business Self Sustainability would be quite easy with this device. The amount of money to construct a single collar still yields very high profitability even at the maximum manufacturing cost. The cost of research and development would be

nonexistent unless the company/business decided to expand to newer devices or different forms of technology.

The goal value that the team predicted it would cost for 1 device is less than fifty dollars.

The current cost of materials for our current design are as follows:

- Temperature Sensor - \$6.40
- MCU - \$11.42
- Wi-Fi Communication - \$14.07
- Accelerometer -\$7.22
- GPS - \$29.95
- Heart Rate Monitor - \$3.53
- Exterior/Casing - \$50
- Power System - \$14.95

The market value of competitors collars is approximately 120-150, average about 130 Dollars. That yields an 80 profit range if we charged the same amount as our competitors. With initial release of our device it has been decided to keep the price slightly lower than our competitors as we do not want to drive the value of the device down on the market.

The amount of effort to mass produce the device would be minimal. The device board would have to be printed, then a human would have to manually install the device into the collar and seal it for shipment. The amount of time needed to order and print the device would take several weeks, and the time to construct a final product would take a few minutes. Overall the amount of time to produce this device is limited by the amount of time it takes the manufacturer to print the board.

Future designs for this product would require a team of engineers to update and improve the design. It would be recommended to keep engineering on staff to troubleshoot potential problems or to update the software on the device.

The engineering team determined that the devices sustainability would be very high. The device will need little to no updating or maintenance. The only real maintenance needed would be changing the battery or charging the device.

The team went through each individual component such as the processor, Wi-Fi adaptor, power system, and the microcontroller and found the product lifetime to be about 1 year of continuous use. This device is designed to experience heavy vibration and stress given the printed board specifications. The device itself should have a very high reliability given we have printed it on a composite board. Product lifetime is limited by the components within the device. This collar can last approximately 10 years of standard use given the estimated lifespan of the components.

It would be suggested that a 2 year warranty be given to the device for the business to properly survive. Given that the device can last 10 years under normal conditions, and 1 year under extreme conditions it would be ideal to have this 2 year window for the user to enjoy the device. Within the device a lifetime timer will be installed so if it is ever mailed back to the manufacturer they are able to diagnose that it died to overuse. In any other situation the engineers associated with the project agree that it is fair to replace the device if a malfunction occurs.

For the final design, the price ended up going higher and some components changed. However, the Doggy Pal Collar still achieved all its goals and the new price still keeps the collar competitive with other similar devices. A better design and testing plan could lower the price point more.

6.0 Project Hardware and Software Design Details

6.1 Initial Design Architectures and Related Diagrams

The TM4C123GH6PM microcontroller comes in a 64 pin package. The Pin Diagram for the TM4C123GH6PM is shown in Figure 6.1-1. The signals for each pin for the TM4C123GH6PM are found in a table starting on page 1369 in the TM4C123GH6PM Datasheet. The table features every signal that can be found on a pin on the microcontroller listed in alphabetical order for easy lookup, along with the pin type and a brief description. The primary signals that will be of concern for the smart collar will be communication signals such as I²C serial data and serial clock, and UART transmit and receive pins. According to table MCU2, I2C0SCL is found on pin 47, I2C0SDA is found on pin 48, U1CTS and U1TX are found on pin 15, and U1RTS and U1RX are found on pin 16. U2TX is on pin 10 and U2RX is on pin 53. The table in the datasheet proved exceptionally helpful when creating the first draft schematic for the smart collar and will be heavily relied upon throughout the entire duration of this project.

The initial design architecture of the smart collar system features two sensors and a communication module connected to the microcontroller via I²C, one sensor connected to the microcontroller via UART, and one sensor connected to the microcontroller via a proprietary digital communication connection. The basic communication layout of the smart collar system is shown in Figure 6.1-2.

Each sensor will collect data from the target object- the dog wearing the smart collar. The data collected will include temperature, position, acceleration, and heart rate. The data will be aggregated by the microcontroller and then sent to the wireless communication module for wireless transmission through a local wireless connection to the web. The end user will be able to view the data in an easy-to-read format on a website. A signal flow block diagram for the smart collar system is shown in Figure 6.1-3. The schematic for the connections in the smart collar system is shown in Figure 6.1-4.

Figure 6.1-1: Pin Diagram of the TM4C123GH6PM (Courtesy of Texas Instruments)

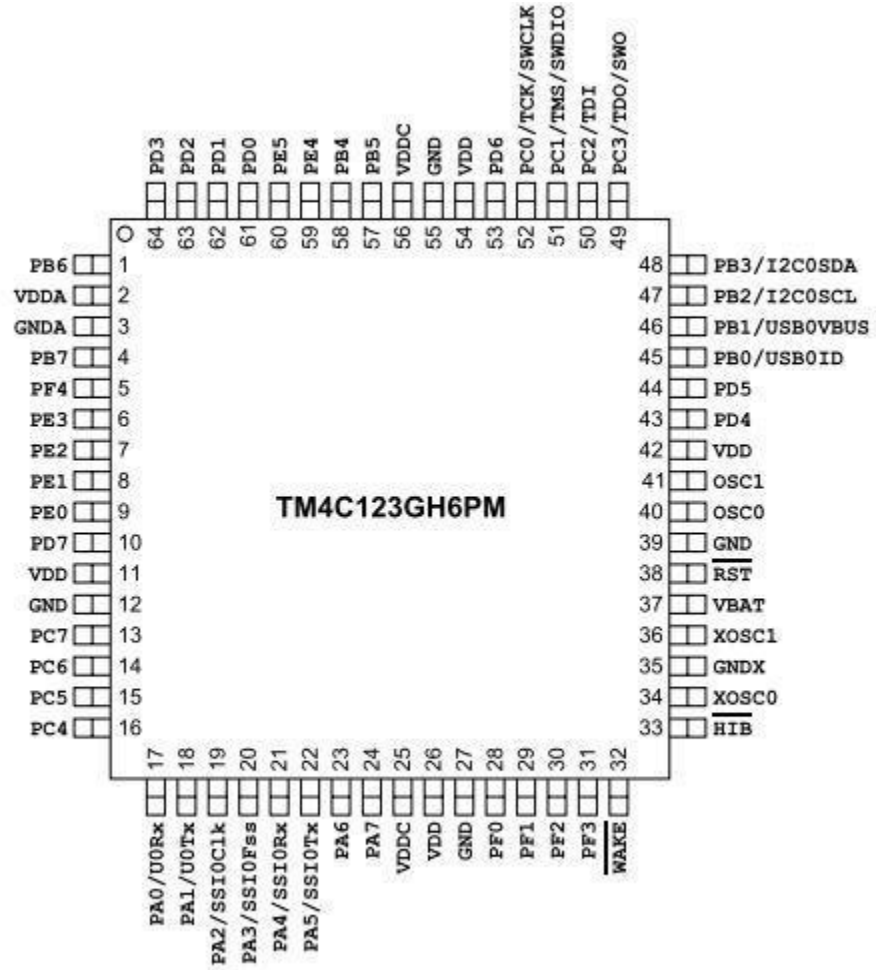

Figure 6.1-2: Communication Configuration of the System

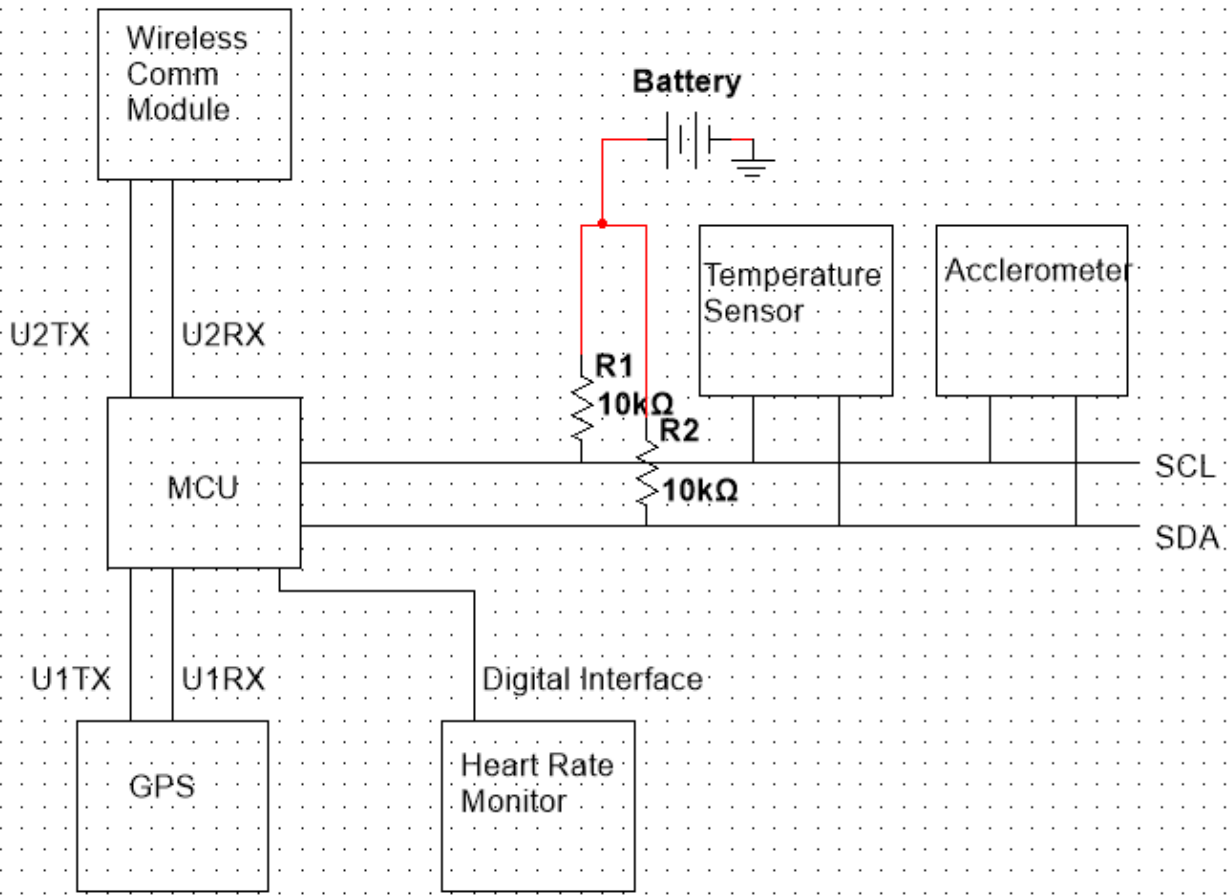

Figure 6.1-3: Signal Flow Block Diagram:

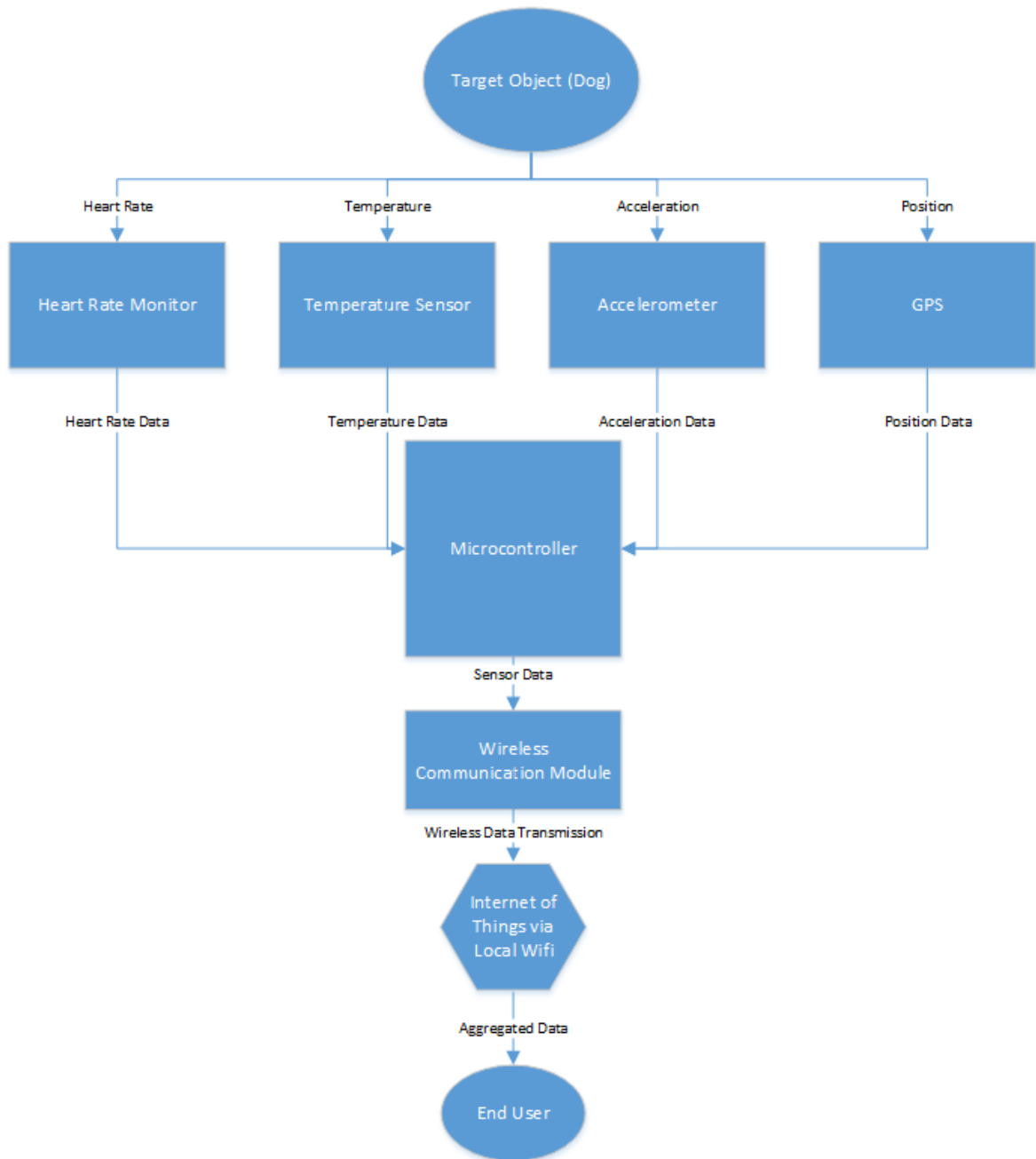

Figure 6.1-4a: Microcontroller Schematic (Figure Courtesy of Texas Instruments)

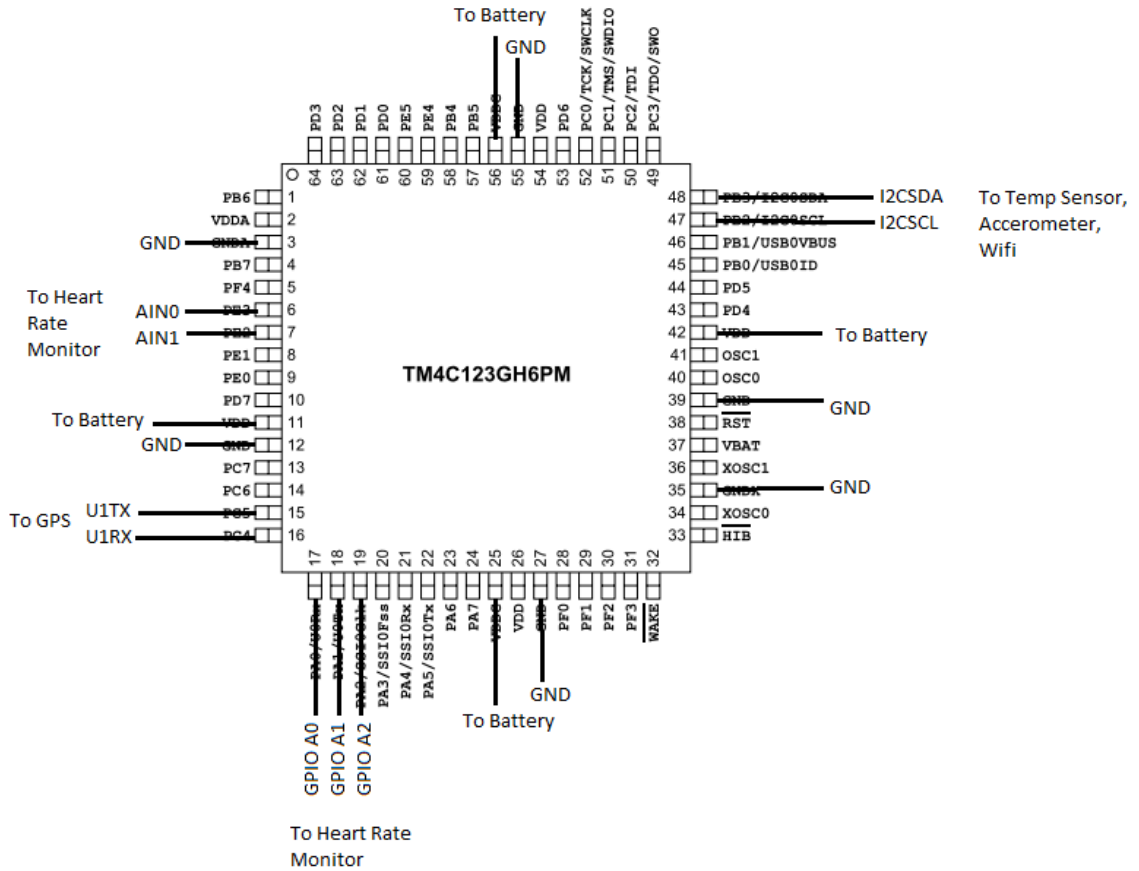

Figure 6.1-4b: Temperature Sensor Schematic (Figure Courtesy of Texas Instruments)

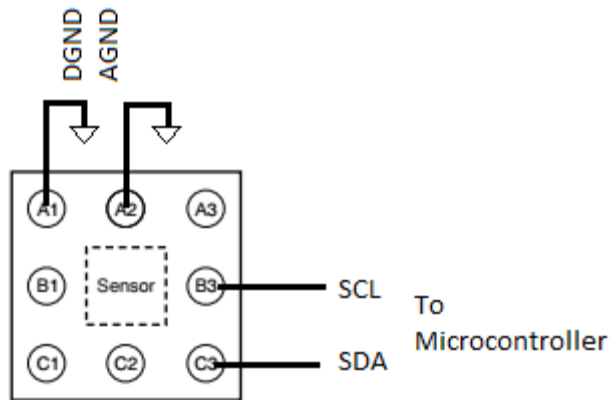

Figure 6.1-4c: Accelerometer Schematic (Permission Pending from Invensense)

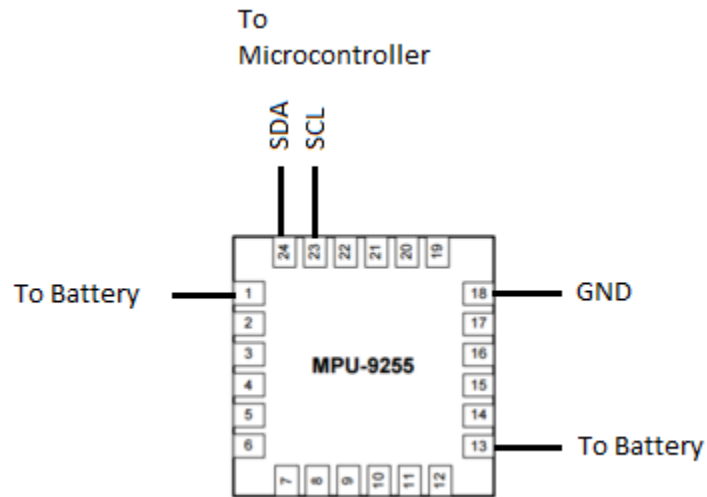

Figure 6.1-4d: Heart Rate Monitor Schematic (Figure Courtesy of Analog Devices)

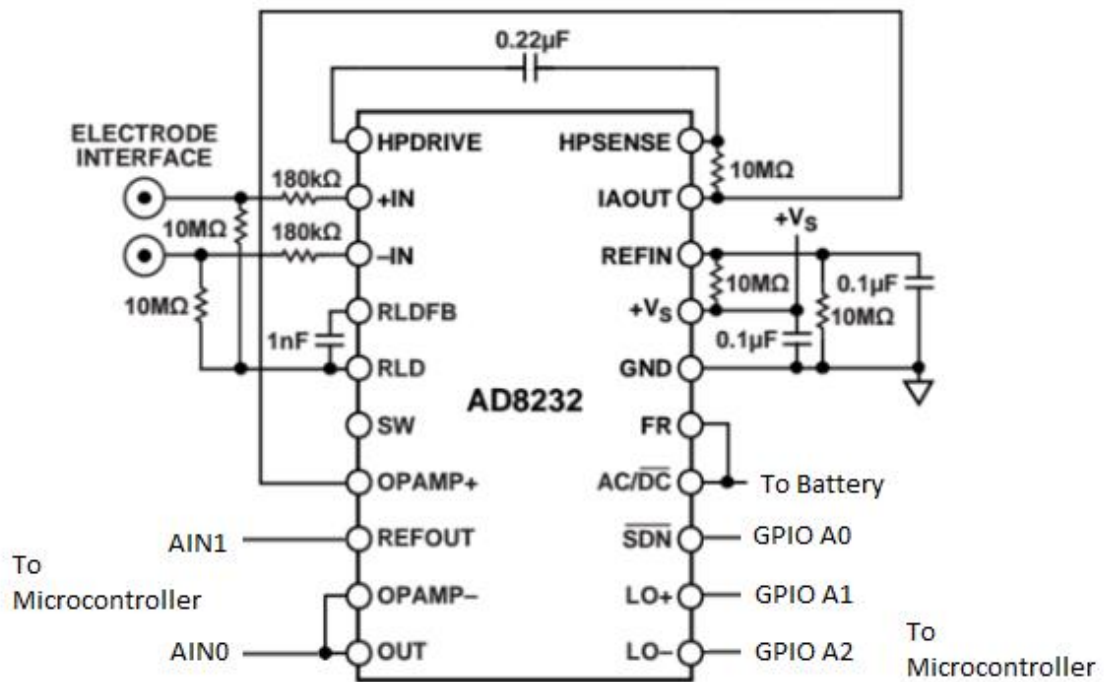
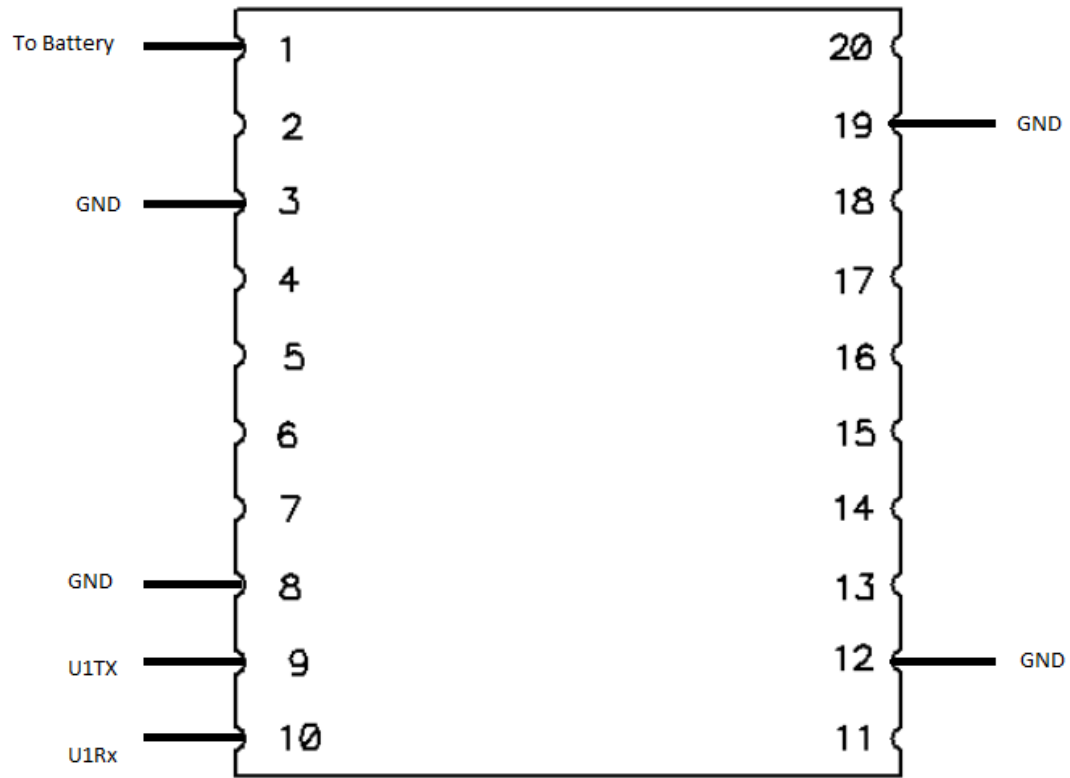

Figure 6.1-4e: GPS Schematic (Figure Courtesy of Adafruit)



The TMP007 will be positioned on the printed circuit board as shown in Figure 6.2-1 such that its sensor is facing upwards through a small viewing port on the interior side of the smart collar directly at the target object. Using its internal thermopile which can be seen in Figure 6.2-2, it will calculate the temperature of the target object and communicate that data to the microcontroller via the I²C bus. The TMP007 will continuously gather temperature data and send it over the I²C bus at a rate of 100 kHz whenever the microcontroller requests it. The TMP007 is capable of sending alerts from pin C2 at certain temperatures, however as of this writing, the alert feature will not be used in this project.

Figure 6.2-1: TMP007 Infrared Viewing Port

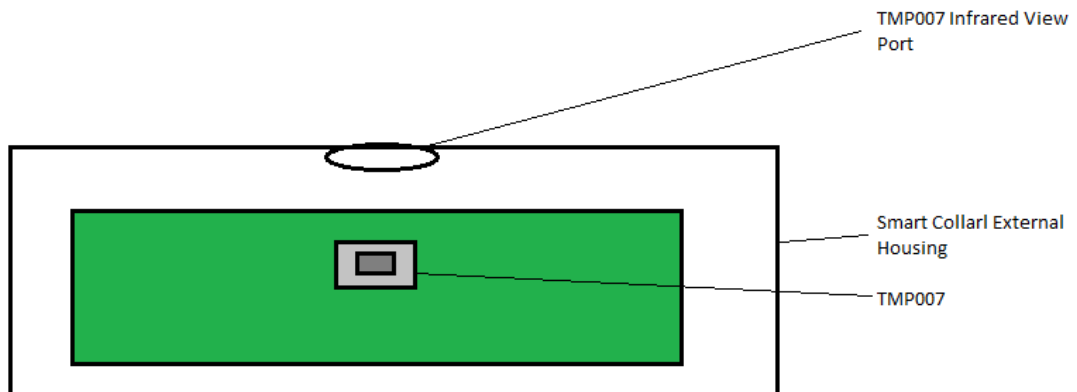
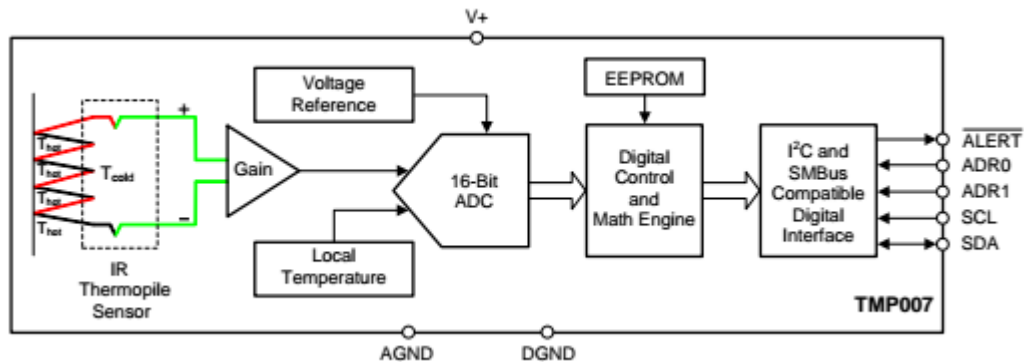

Figure 6.2-2: Functional Block Diagram of the TMP007 (Courtesy of Texas Instruments)



6.3 Heart Rate Monitor Subsystem

The heart rate monitor circuit is based around the idea of electrocardiography. This is the process of measuring the electrical activity in the heart by using electrodes put on the body. The electrodes are used to detect the small electrical changes on the body that are caused by the heart muscle depolarizing with each heartbeat. The electrocardiography can be separated into three sections. The first section is the PR section. This section is where the first wave is created by

the electrical impulse moving from the right atrium to the left atrium. The second section is the QRS section. In this section the right ventricle and the left ventricle start to pump. The final section is the ST section. This section is where the left ventricle and the right ventricle wait to be re-polarized. Figure 6.3-1 below shows an example of an EKG waveform from Wikipedia.

Figure 6.3-1: EKG Waveform (Courtesy of Wikipedia)

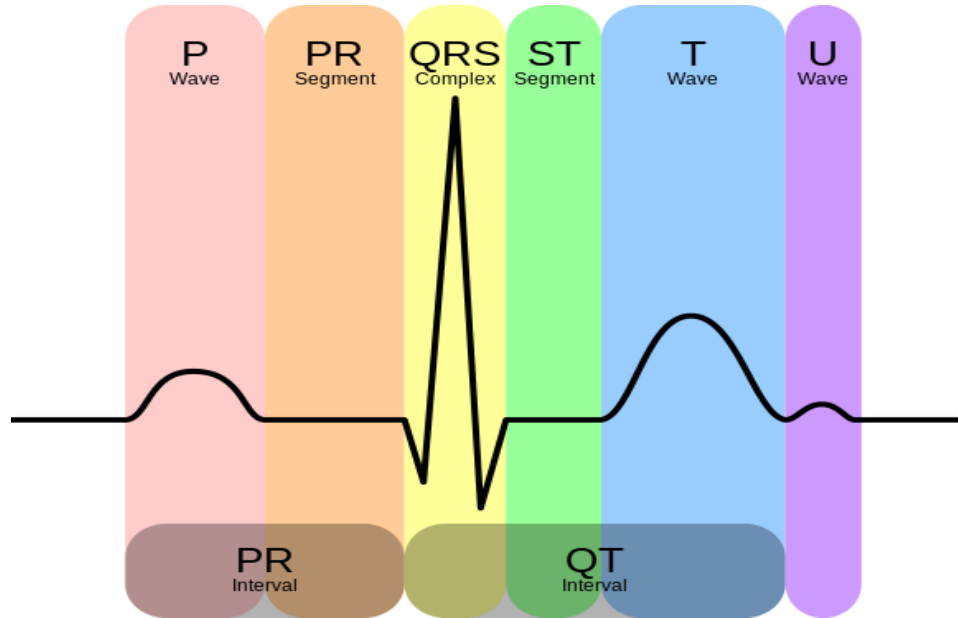

At the heart of the circuit is the AD8232 chip that can measure electrocardiography. Figure 6.3-2 shows the block diagram of the AD8232 chip from Analog Devices. This chip has many features that will be important for the circuit. Table 6.3-1 shows the short pin function descriptions for the AD8232 chip from Analog Devices. These features include a low supply current, a shutdown pin and a single-lead ECG front end that is fully integrated. The AD8232 has an instrumentation amplifier that applies gain and filters out near dc signals at the same time. This ability allows the AD8232 chip to amplify small ECG signals by a factor of 100. The circuit will run at 3.3V and the shutdown pin will be used to reduce the power usage and put the circuit into a low power shutdown mode when not being used. While in shutdown mode the AD8232 chip takes less than 200 nA of current. This will be useful to save battery power on the Doggy Pal Collar and help the other components on the collar last longer. The circuit will also use an electrode cable with pads that attaches to the body in order to sense the electrical activity that comes from the heart. When the electrode cable pads are connected to the body the circuit will produce an electrocardiogram waveform that is similar to the figure above using an operational amplifier output pin on the circuit. The circuit can also detect when the electrode cable pads are not connected to the body using the leads off comparator output pin. When the electrode cable pads are not connected, the electrocardiogram waveform will

show a flat line in the waveform. This can help trouble shoot the heart rate monitor and let users know that the heart rate monitor is not functioning properly.

Figure 6.3-2: AD8232 Functional Block Diagram (Courtesy of Analog Devices)

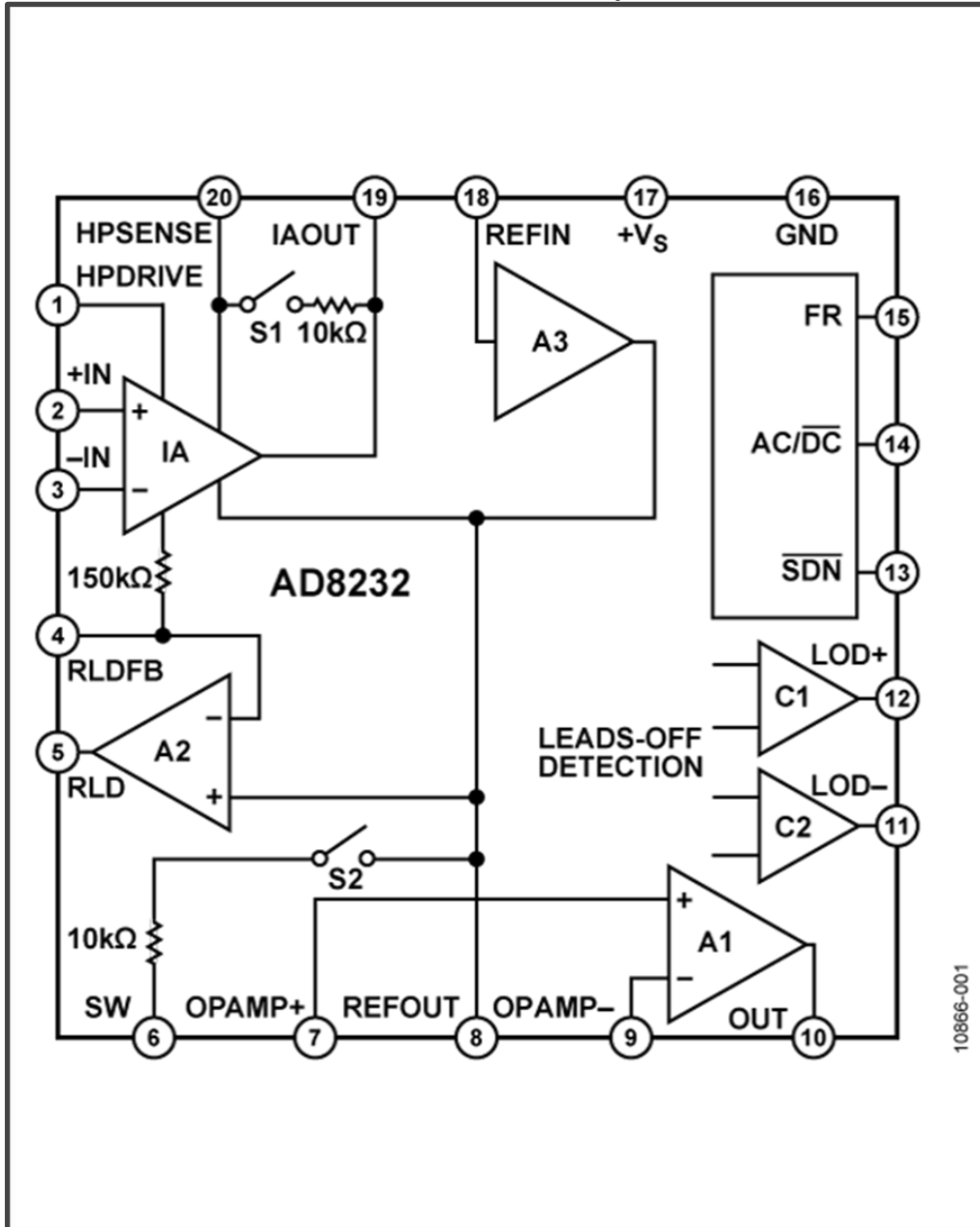

Table 6.3-1: Pin Function Short Descriptions (Courtesy of Analog Devices)

Pin Number	Mnemonic	Description
1	HPDRIVE	High-Pass Driver Output.
2	+IN	Instrumentation Amplifier Positive Input.
3	-IN	Instrumentation Amplifier Negative Input.
4	RLDFB	Right Leg Drive Feedback Input.
5	RLD	Right Leg Drive Output.
6	SW	Fast Restore Switch Terminal.
7	OPAMP+	Operational Amplifier Noninverting Input.
8	REFOUT	Reference Buffer Output.
9	OPAMP-	Operational Amplifier Inverting Input.
10	OUT	Operational Amplifier Output.
11	LOD-	Leads Off Comparator Output.
12	LOD+	Leads Off Comparator Output.
13	<u>SDN</u>	Shutdown Control Input.
14	<u>AC/DC</u>	Leads Off Mode Control Input.
15	FR	Fast Restore Control Input.
16	GND	Power Supply Ground.

17	+V _s	Power Supply Terminal.
18	REFIN	Reference Buffer Input.
19	IAOUT	Instrumentation Amplifier Output Terminal.
20	HPSENSE	High-Pass Sense Input for Instrumentation Amplifier.

A microcontroller will collect the data from the circuit and send that data to the Internet of Things platform that is setup with the Doggy Pal Collar. The Internet of Things platform will allow users to see the electrocardiogram waveform from the circuit in real-time. One of the websites for the Internet of Things platform that is being used alongside the Doggy Pal Collar is dweet.io. This website will monitor the heart rate monitor data. If the data is outside certain boundaries, it will send a message to the user telling them to go check on their dog because there could be a problem. Figure 6.3-3 shows the flowchart of the heart rate monitor as a component of the Doggy Pal Collar. A schematic for the configuration of the heart rate monitor can be seen in Figure 6.3-4.

Figure 6.3-3: Heart Rate Monitor Component Flowchart

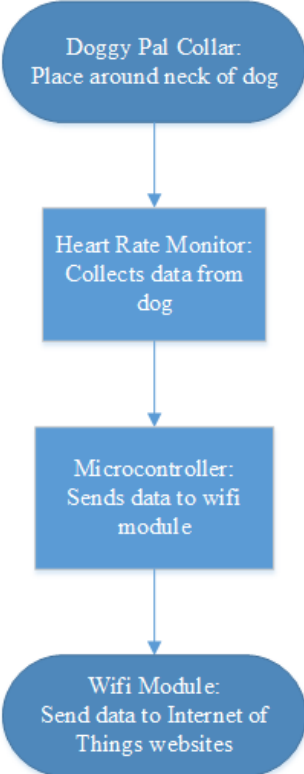
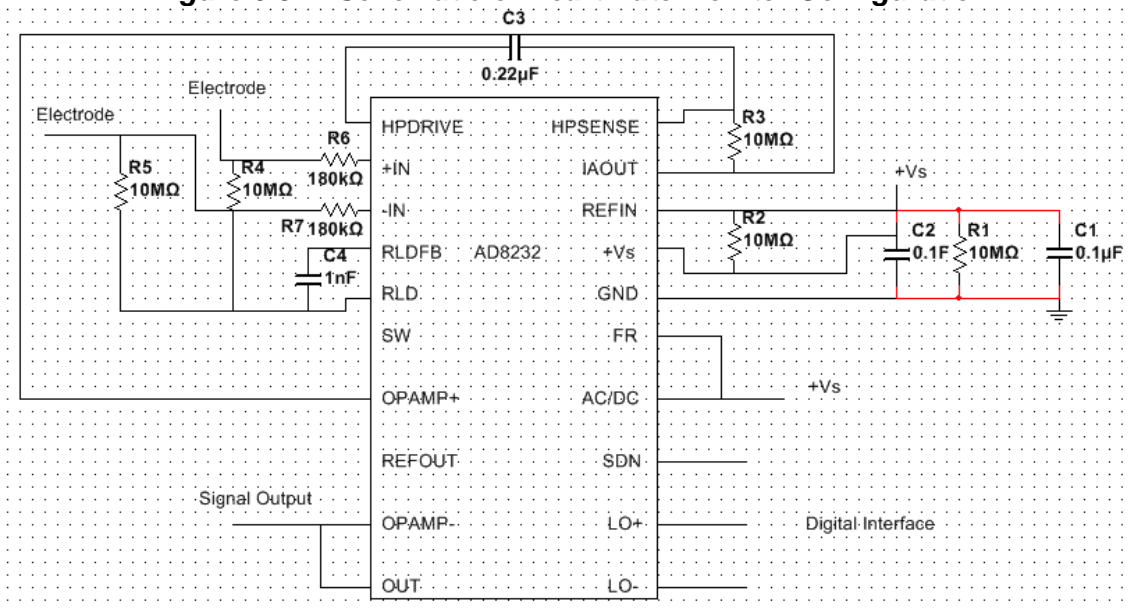

Figure 6.3-4: Schematic of Heart Rate Monitor Configuration:



For the final project, the Pulse Sensor Amped was used in place of the AD8232. The subsystem for the Pulse Sensor Amped is similar to the AD8232. However, one major difference is the Pulse Sensor is a plug and play device so it takes less setup and it uses pulse oximetry to find the heart rate.

6.4 Accelerometer Subsystem

The accelerometer that was chosen is an Invensense Inc 9 Axis Accelerometer labeled the MPU-9255. This device was suggested by our professor at UCF. The team also looked at many other accelerometers but the team felt this one fit our needs. The constraints involved in selection were weight, size, functionality, and cost. The Invensense device performed well, weighed very little, and was very small so overall its performance was a plus. On the other hand this device cost a little bit more than the other devices available, but overall it was found that the user would enjoy having a lighter device overall so it was decided to stick with the Invensense accelerometer.

Within the device there are 3 sets of 3 axis control units containing 9 axis total. The first die contains a 3 axis gyroscope and a 3 axis accelerometer, the other die contains a 3 axis magnetometer. The diagram of Axis of Orientation can be seen in Figure 6.4-1 and 6.4-2.

**Figure 6.4-1 Axis Orientation of the Accelerometer and Gyroscope
Given Dimensions are 3x3x1mm**

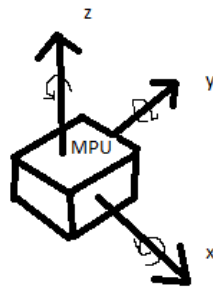
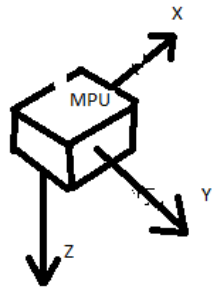
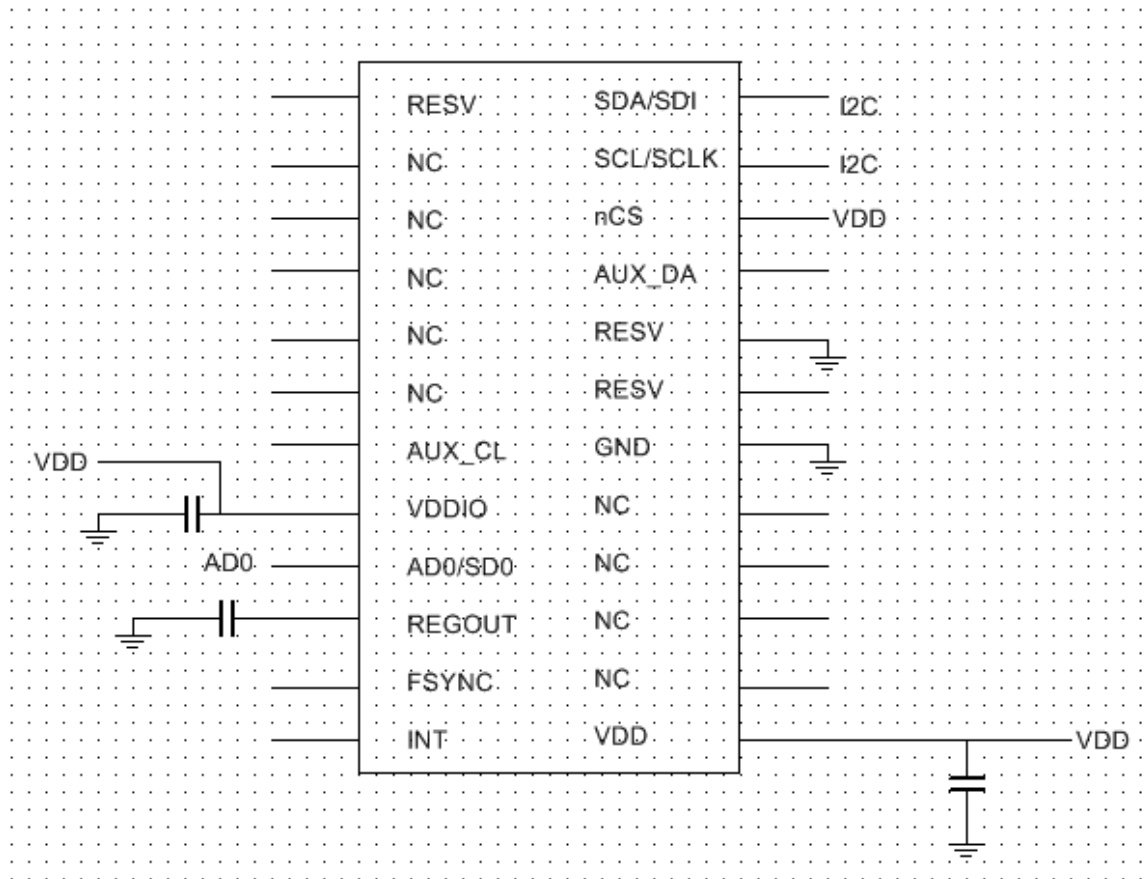

Figure 6.4-2, Axis Orientation



For digital to analog conversion this device contains nine 16 bit analog to digital converters of digitizing the gyroscope outputs, accelerometer outputs, and for the magnetometer outputs. A schematic for the device is shown in Figure 6.4-3.

Figure 6.4-3: Accelerometer configuration schematic



The temperature range for precision device outputs ranges from 40 Celsius to 85 Celsius. The operating voltage range (VDD) is from 2.4v to 3.6v. The MPU-9255 includes a support module for AAR, automatic activity recognition which includes built in software that can detect when a user is walking, running, sleeping, etc. Our group found that this kind of built in technology is perfect for the Doggy Pal Collar. Although the integrated software was designed for humans walking and running, it gave us an ideal starting point to change and integrate the software for our needs.

Gyroscope Features:

- X, Y, and Z digital output sensors
- Programmable within X degrees per second function
- Programmable Low Pass Filter
- 3.2mA Operating Current
- Accelerometer Features
- Triple Axis Control
- Programmable within +/- (g) rates
- 450µA operating current
- Low power operation current mode
- Wake on motion for power saving applications

Magnetometer Features:

- 3 axis hall effect magnetic sensor
- 280 μ A operating current
- Measurement range \pm 4800 μ T

Feature Overview:

- 3.5mA Operating Current when running all 9 Axis Functions
- Additional bus for reading external sensors
- VDD voltage operation range of 2.4V-3.6V
- Dimensions of 3x3x1mm optimal for small devices
- 10000g Shock tolerance
- Exceptional long term life testing

Given the above specifications it was found that this device was suitable for the design. Not only is the device able to meet the required specifications it is designed and durable for this type of application. This device is low cost, reliable, space efficient, and high quality. As you can see from Table 6.4-1 below, the pin usage and diagram are given.

Table 6.4-1: Pins of the Accelerometer

Pin #	Pin Name	Pin Description
1	RESV	Reserved
7	AUX_CL	Master Serial Clock
8	VDDIO	Digital supply voltage
9	AD0/SDO	Slave Address
10	REGOUT	Regulator filter cap connection
11	FSYNC	Frame sync digital input
12	INT	Interrupt digital output
13	VDD	Power supply Voltage
18	GND	Power supply Ground
19	RESV	Reserved
20	RESV	Reserved, connect to ground
21	AUX_DA	Maser serial data for external

22	nCS	Chip Select SPI mode only
23	SCL/SCLK	Serial Clock
24	SDA/SDI	Serial data input, serial data
2-6, 14-17	NC	Not internally connected

Figure 6.4-4, Pin Diagram of Invensense MPU-9255

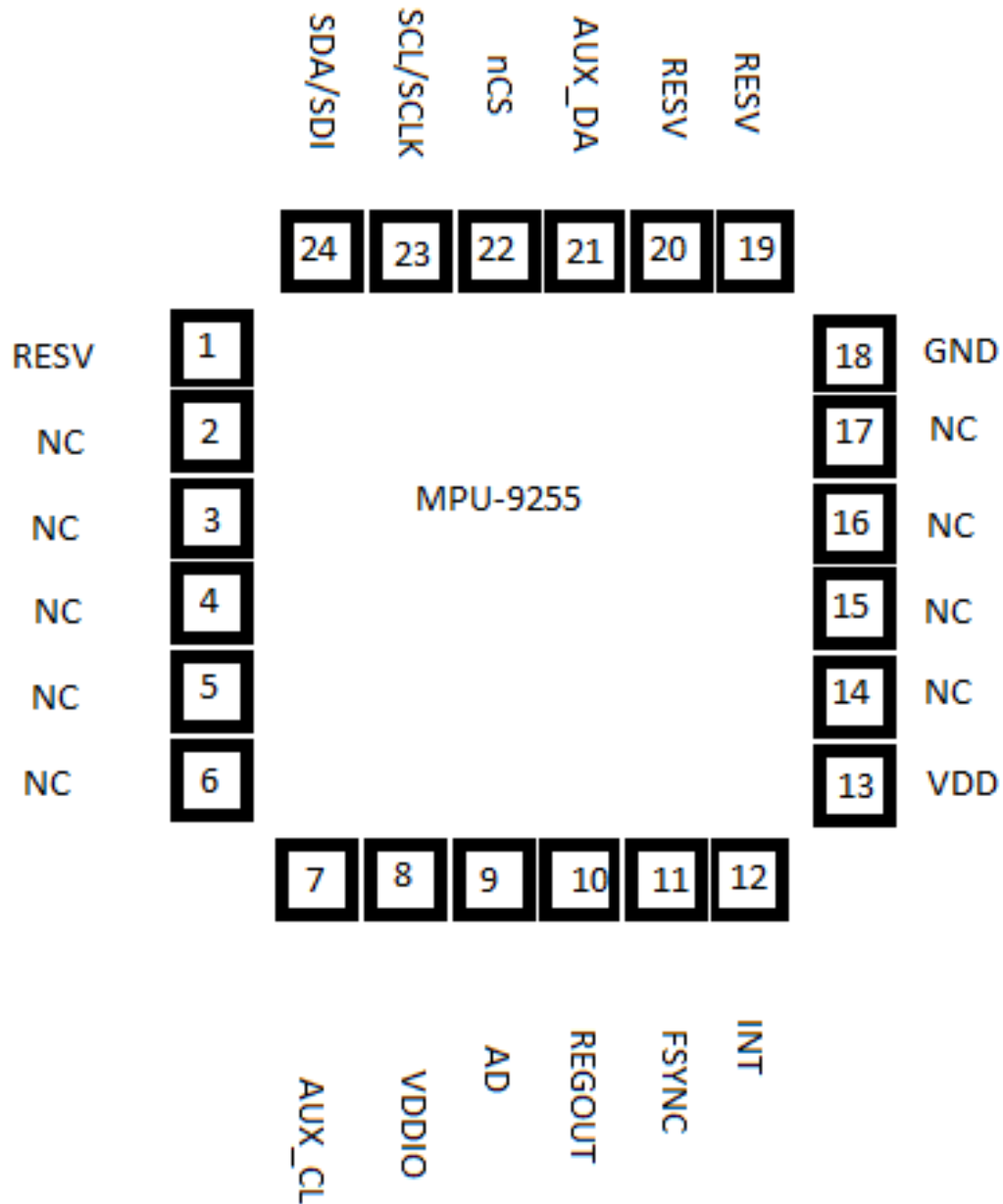
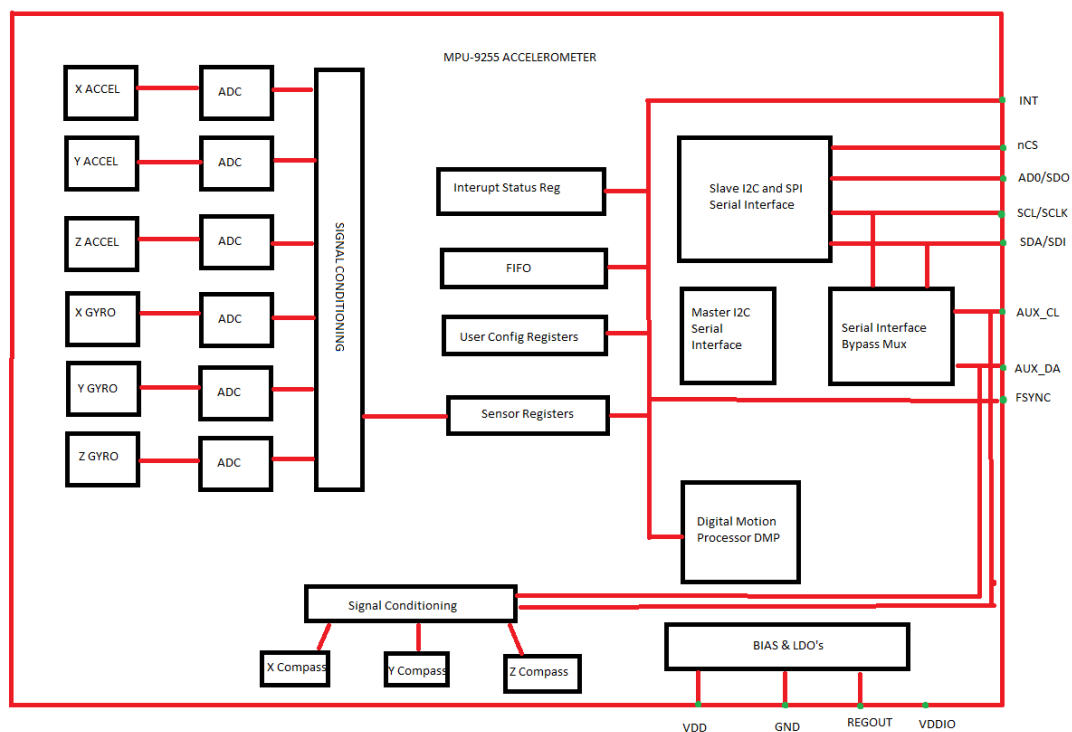

Figure 6.4-5, Internal diagram of the MPU-9255



As you can see from Figure 6.4-4 there are 6 signal registers available for the 6 axis of control with an addition axis that operates the temperature sensor. I do not believe the design will be using the temperature sensor that is included within this device as the team needs a more accurate reading more directly off the animal.

It was recommended by our professor to use the Invensense accelerometer due to its specifications. This accelerometer is the most advanced the group had looked at. It has a low running voltage and it was found to give us the most information out of any device. In addition it comes with a built in thermometer in which the design can use as a reference temperature for our animal temperature sensor.

- | | |
|---------------|--------------------------------------------------------|
| Sensing Axis: | X, Y, Z, Compass, rotational |
| Acceleration: | 2 g, 4 g, 6 g, 8 g, 16g |
| Sensitivity: | 256 count/g, 341 count/g, 512 count/g,
1024 count/g |

Output Type:	Digital
Interface Type:	I2C
Resolution:	12 bit
Supply Voltage - Max:	3.6 V
Supply Voltage - Min:	1.7 V
Package / Case:	LGA-16
Maximum Operating Temperature:	+ 85 C
Minimum Operating Temperature:	- 40 C

For the final paper, the Freescale MMA8451Q chip was used instead of the Invensense chip. The subsystem for both accelerometers would be similar, however the MMA8451Q has less features compared to the Invensense. This won't be a problem because both sensors can find the X,Y, and Z position of the dog and that was the main feature for the Doggy Pal Collar.

6.5 GPS Subsystem

Once the MTK3339 chipset has passed the testing phase it can be implemented into the completed system and start tracking. This high-quality, quick-to-fix, -165 dBm sensitivity receiver will make tracking the dog's location simple and the small size will make implementation effortless. The pin layout in Figure 6.5-1 shows in detail how the GPS chip works and, in Figure 6.5-2, what each pin is assigned to do and how it will be used for this project. When the microcontroller is wired to the RX and TX pins it can command the GPS to start. This chip works by using the built in antenna to send and receive signals.

Figure 6.5–1 Chip System Block Diagram (Courtesy of Adafruit)

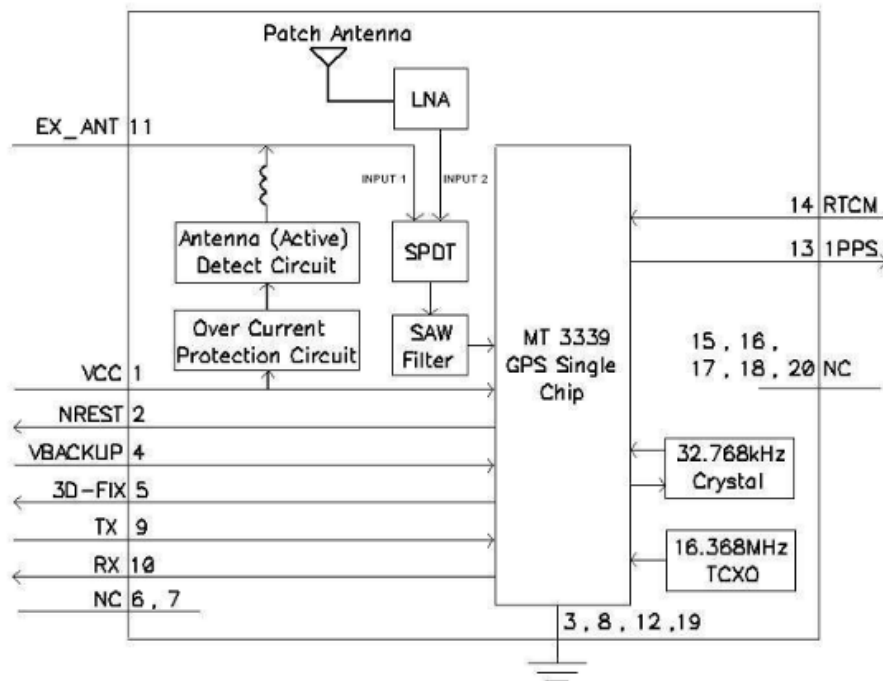
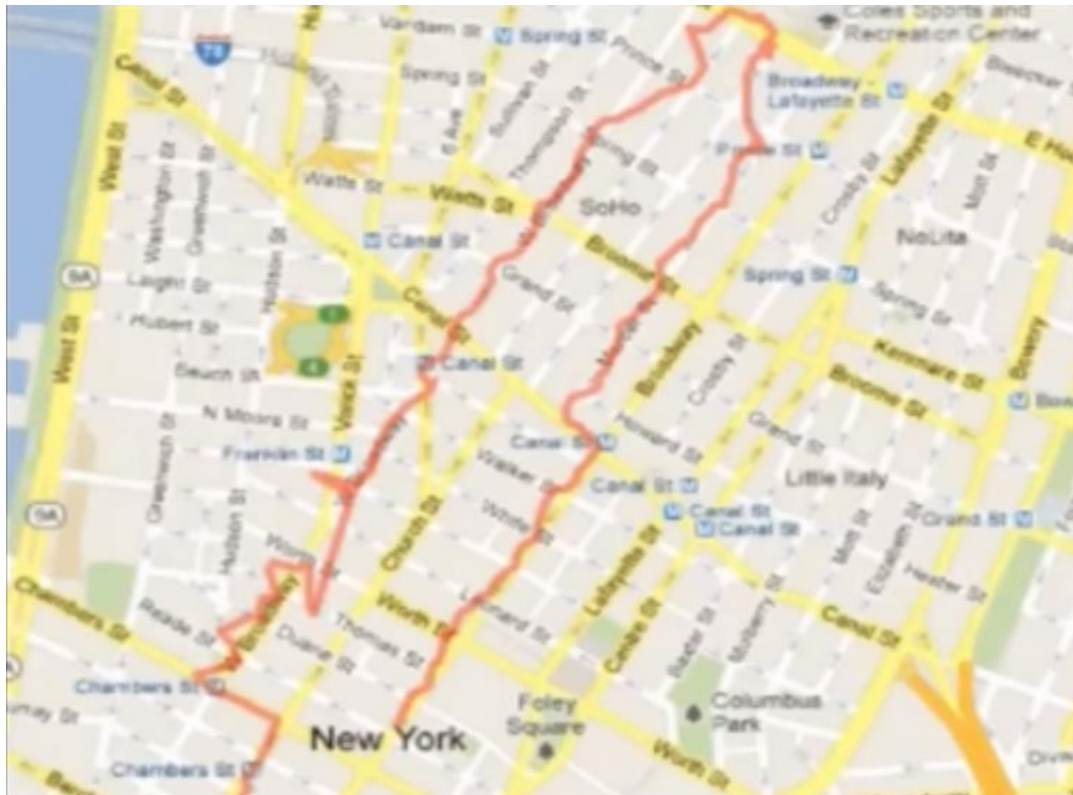

Figure 6.5–2 Pin Layout for MTK3339 (Courtesy of Adafruit)

Pin	Name	I/O	Description & Note
1	VCC	PI	Main DC Power Input
2	NRESET	I	Reset Input, Low Active
3	GND	P	Ground
4	VBACKUP	PI	Backup Power Input for RTC & Navigation Data Retention
5	3D-FIX	O	3D-Fix Indicator
6	NC	--	Not Connect
7	NC	--	Not Connect
8	GND	P	Ground
9	TX	O	Serial Data Output for NMEA Output (UART TTL)
10	RX	I	Serial Data Input for Firmware Update (UART TTL)
11	EX_ANT	I PO	External active antenna RF input. DC power from VCC and provide for external active antenna.
12	GND	P	Ground
13	1PPS	O	1PPS Time Mark Output 2.8V CMOS Level
14	RTCM	I	Serial Data Input for DGPS RTCM Data Streaming
15	NC	--	Not Connect
16	NC	--	Not Connect
17	NC	--	Not Connect
18	NC	--	Not Connect
19	GND	P	Ground
20	NC	--	Not Connect

When installed the MTK3339 chip should quickly find a fix and send out the echo signal. This GPS chip will then decode the raw data that is received from the located satellites and automatically log this data. Since the data does not log unless there is a fix, this decreases the chance of confusing or inaccurate information. This GPS also comes with software that can take this logged data and create a google-map-like graph with the path that was taken highlighted for easy viewing as shown in Figure 6.5–3:

Figure 6.5 – 3 GPS Path Tracking (Courtesy of Adafruit)



When implemented into the Doggy Pal Collar system the GPS is then able to present all this information easily and quickly. How the GPS system will work with the microcontroller is shown in the Figure 6.5 – 4. First a microcontroller will send the GPS MTK3339 chip the codes to activate it. In this code the first part will be very similar to the Adafruits “echo” code used for the testing stage. This code will command the GPS to do what it was built to do; send a signal to locate, at least four, satellites and receive the return signal for the located satellites. Once the return signal is received the decoding of the raw data can begin to arrange the information into longitude, latitude, height, date and time categories. Using the software that comes with the MTK3339 chip, the data will create the google map like graph of the path that was traveled. The second part of the code will send this map and logged data to the Wi-Fi component which will send the data to the

Internet of Things. All this information will then be able to be viewed in live time to help the owner keep track of where their furry friend is anywhere and anytime of the day. Figure 6.5-5 shows a schematic of the GPS module for this project.

Figure 6.5-4: GPS System Flowchart

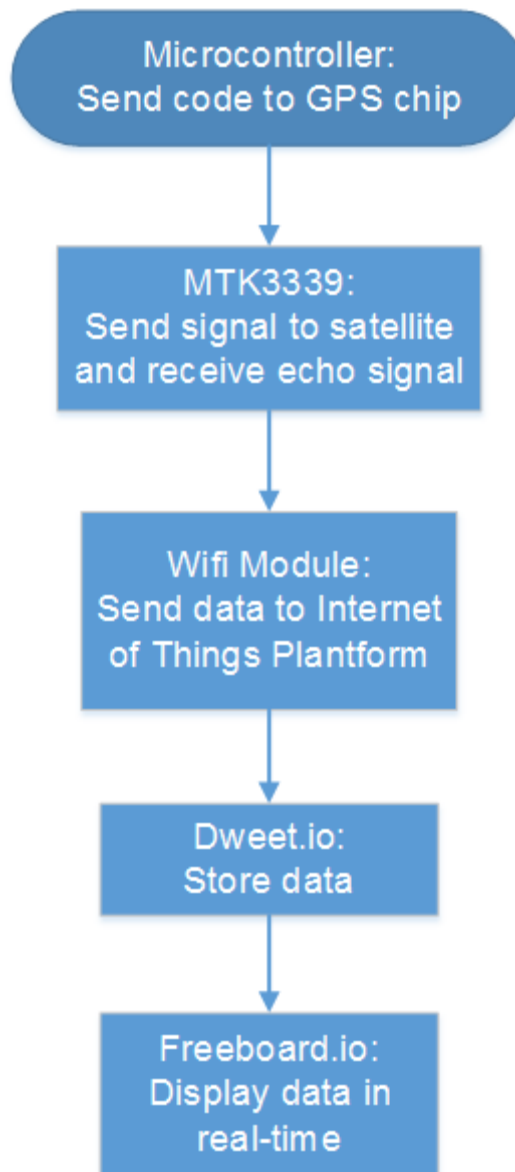
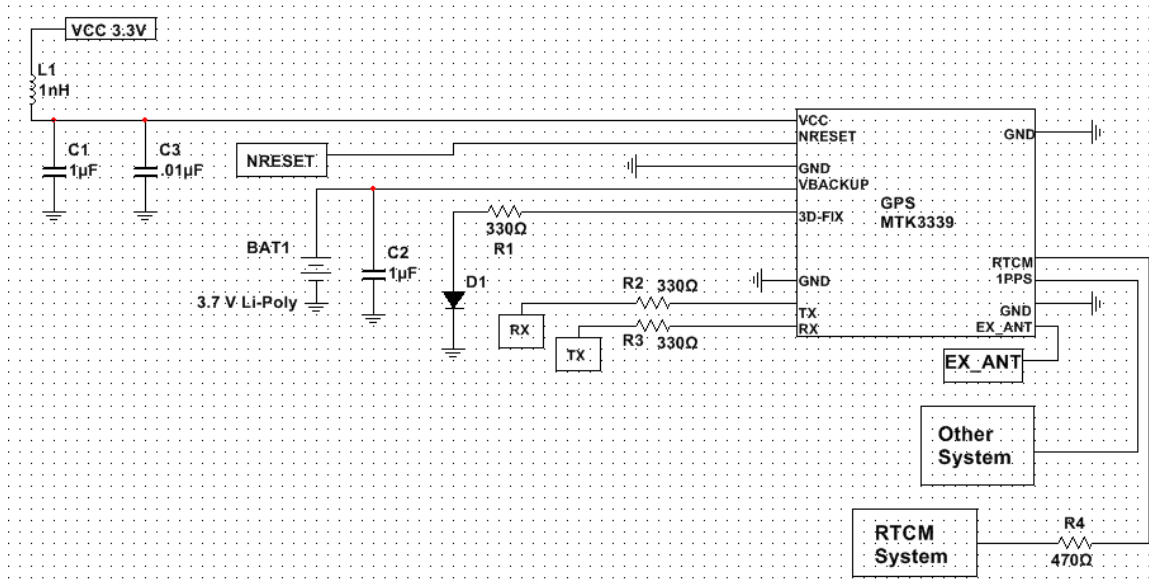

Figure 6.5-5: GPS Schematics



6.6 Microcontroller Programming Plan

The TM4C123GH6PM microcontroller will be connected via I²C to the TMP007 temperature sensor and the accelerometer. The configuration of the I²C bus for this connection is shown in Figures 6.6-1 and 6.6-2. The microcontroller will be designated as one master, and the wireless communication module will be designated as the second master. The temperature sensor and accelerometer will be designated as slaves. The GPS module will be connected via UART1 to the microcontroller, with a Baud rate of 9600, 1 stop bit, and no parity bit. The wireless communication module will be connected to the microcontroller via UART2 with the same settings as UART1. The heart rate monitor will be connected via a digital communication interface through the GPIO pins which uses a proprietary protocol. The code to use this protocol is provided by the chip manufacturer. The microcontroller will receive data from the temperature sensor, heart rate monitor, accelerometer, and the GPS, and transmit data to the wireless communication module for wireless transmission. The I²C bus on the TM4C123GH6PM microcontroller is capable of running at speeds of 100 kbps, 400 kbps, 1 Mbps, or 3.33 Mbps. The speed chosen for the bus must match the speed of all devices on the bus. The initial speed chosen will be 100 kbps to test for compatibility or sampling rate issues. Speed will be increased if it is necessary and feasible.

The parameters that control the I²C clock rate are CLK_PRD (system clock period), TIMER_PRD (programmed value in I2CMTPR register), SCL_LP (low phase of serial clock), and SCL_HP (high phase of serial clock). The following

formula from the TM4C123GH6PM datasheet is used to calculate the I²C clock period:

$$\text{SCL_PERIOD} = 2 \times (1 + \text{TIMER_PRD}) \times (\text{SCL_LP} + \text{SCL_HP}) \times \text{CLK_PRD}$$

Sample values for these parameters from the microcontroller datasheet are shown in Table 6.6-2. The initial configuration will be a 4 MHz system clock and timer period set to 0x01 in order to achieve the desired 100 kbps speed. As each of the sensors on the I²C bus makes measurements and collects data to transmit, they will set a bit to request an interrupt. The microcontroller will poll for these interrupts and collect the data as it comes in. The microcontroller will then communicate with the wireless communication module in order to have the data transmitted at regular intervals.

Figure 6.6-1: TM4C123GH6PM I²C Block Diagram (Courtesy of Texas Instruments)

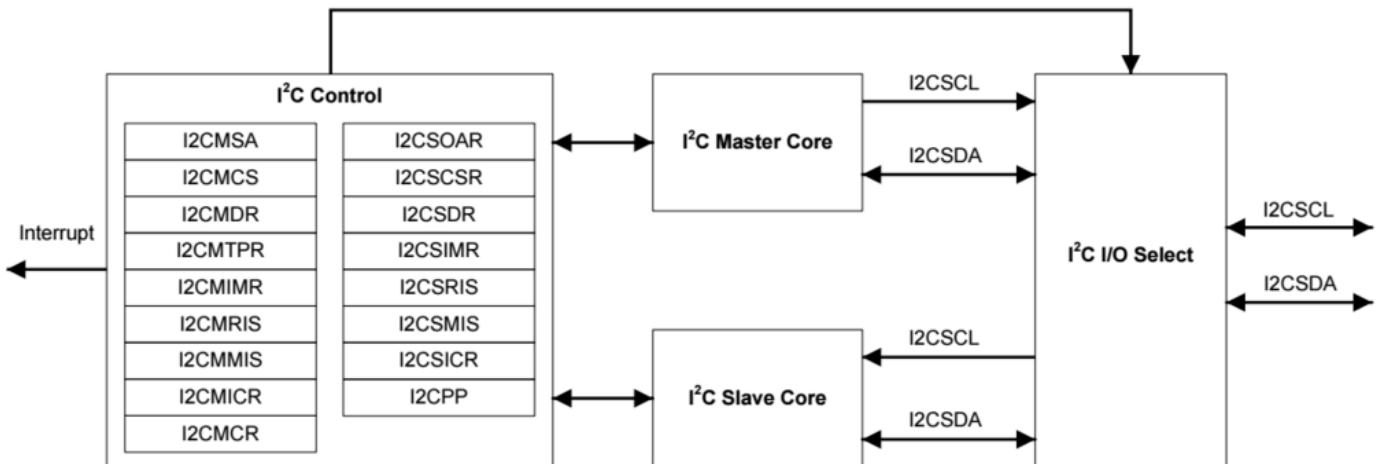

Table 6.6-1: TM4C123GH6PM I²C Signals (Courtesy of Texas Instruments)

Pin Name	Pin Number	Pin Mux / Pin Assignment	Pin Type	Buffer Type ^a	Description
I2C0SCL	47	PB2 (3)	I/O	OD	I ² C module 0 clock. Note that this signal has an active pull-up. The corresponding port pin should not be configured as open drain.
I2C0SDA	48	PB3 (3)	I/O	OD	I ² C module 0 data.
I2C1SCL	23	PA6 (3)	I/O	OD	I ² C module 1 clock. Note that this signal has an active pull-up. The corresponding port pin should not be configured as open drain.
I2C1SDA	24	PA7 (3)	I/O	OD	I ² C module 1 data.
I2C2SCL	59	PE4 (3)	I/O	OD	I ² C module 2 clock. Note that this signal has an active pull-up. The corresponding port pin should not be configured as open drain.
I2C2SDA	60	PE5 (3)	I/O	OD	I ² C module 2 data.
I2C3SCL	61	PD0 (3)	I/O	OD	I ² C module 3 clock. Note that this signal has an active pull-up. The corresponding port pin should not be configured as open drain.
I2C3SDA	62	PD1 (3)	I/O	OD	I ² C module 3 data.

Figure 6.6-2: I²C Bus Configuration (Courtesy of Texas Instruments)

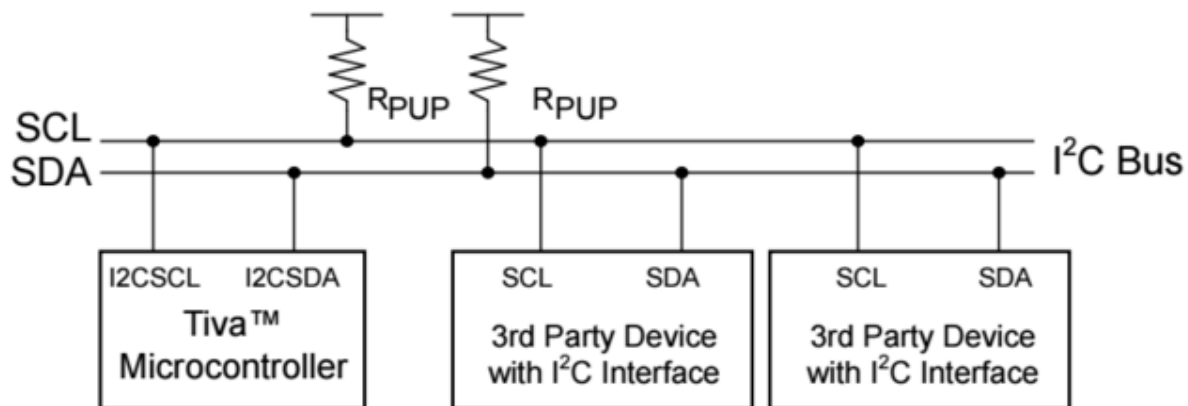

Table 6.6-2: *PC Timer Periods (Courtesy of Texas Instruments)*

System Clock	Timer Period	Standard Mode	Timer Period	Fast Mode	Timer Period	Fast Mode Plus
4 MHz	0x01	100 Kbps	-	-	-	-
6 MHz	0x02	100 Kbps	-	-	-	-
12.5 MHz	0x06	89 Kbps	0x01	312 Kbps	-	-
16.7 MHz	0x08	93 Kbps	0x02	278 Kbps	-	-
20 MHz	0x09	100 Kbps	0x02	333 Kbps	-	-
25 MHz	0x0C	96.2 Kbps	0x03	312 Kbps	-	-
33 MHz	0x10	97.1 Kbps	0x04	330 Kbps	-	-
40 MHz	0x13	100 Kbps	0x04	400 Kbps	0x01	1000 Kbps
50 MHz	0x18	100 Kbps	0x06	357 Kbps	0x02	833 Kbps
80 MHz	0x27	100 Kbps	0x09	400 Kbps	0x03	1000 Kbps

For the final paper, the Atmega328p chip was used for the Doggy Pal Collar. This chip was very similar to the Texas Instruments chip with similar features and the subsystem would be similar as well. One of the main reasons for the change was the use of the Arduino Uno for testing and prototyping and setting up code to work with the Atmega328p chip.

6.6.1 Internet of Things Subsystem

The Internet of Things (IoT) is a platform which allows information to be shared and manipulated easily. This is accomplished by using wireless, embedded and other networking technology that allows objects to collect data in their local area of operation and send this data over a network. These objects can be anything including humans, animals and inanimate objects. The “Things” can be any type of device or sensor that collects data such as a temperature sensor or a heart rate monitor. These Things can collect data and using networking technology such as Wi-Fi, Bluetooth or Ethernet can send this data to other devices. This data can also be sent to the cloud where the data can be manipulated even further. This can be useful because data can be accessed and monitored in real-time over a network without having to retrieve a device first. In addition to sending information, the Internet of Things platform allows for data to be received by the local devices and sensors as well as allowing these “Things” to be manipulated across networking technologies. The technique is the same, the data or instructions are sent over a network using Wi-Fi, Bluetooth or other networking technology to the embedded system that controls the devices or sensors on the object. This can be useful because updates and new instructions can be received by the devices changing how they operate in real-time without having to retrieve the devices first.

The Doggy Pal Collar will use the Internet of Things platform to communicate data to the owner of the collar. A Wi-Fi module on the collar will transfer data from the temperature sensor, the accelerometer sensor, the heart rate monitor and the GPS sensor to the cloud. Once this data is in the cloud it will be manipulated and displayed with the help of two Internet of Things websites in the cloud called freeboard.io and dweet.io. These two websites will help display the information in an easy to ready manner on the internet where anyone can access the data in real-time. The data can be displayed in many different forms and help the owner and veterinarians track important data overtime and monitor the behavior of the dog when the owner is away. By using the Internet of Things to display this data, anyone with an internet access can easily see the information the Doggy Pal Collar is sending to the cloud. This can be done without removing the collar from the dog because as long as the dog is within range of a home network the collar will continue to transfer data to the cloud. Another advantage of using the Internet of Things platform is the dweet.io website will be able to send alerts to the owner of the collar in case the heart rate monitor picks up abnormal readings such as erratic heart rate. This information can be sent straight to a smartphone and alert the owner in real-time. Erratic heart rates can be very dangerous for the dog and dweet.io can monitor the incoming data by setting certain boundaries for the data with programming code. If the heart rate data stays within the boundaries, no alert message will be sent.

It would also be possible to use the Internet of Things platform to send data to the Doggy Pal Collar to update firmware or change the type of data that is being displayed without having to remove the Doggy Pal Collar and take it apart. A veterinarian could also access the Doggy Pal Collar over the Internet of Things and customize the collar to specific needs they are looking for right from a computer in their office without even having to wait to see the dog in person. The Internet of Things platform was chosen because of these advantages it presents over other methods of collecting and displaying data such as a phone application which could be hard to customize for the needs of the dog. This platform provides all the services necessary to help make the Doggy Pal Collar a reliable device that pet owners and veterinarians can count on to help monitor animals. Freeboard.io is a cloud based website that can be used with the Internet of Things platform that helps display data in real-time. The idea behind the website is to create easy to use dashboards that can display device and sensor information that has been uploaded to the cloud using Wi-Fi or other networking technology. The website works with other API websites such as dweet.io and is open source and each Freeboard that is created comes with a URL that can be shared on social networks, email and SMS. It is also free to use and free to access, with payment plans available depending on the needs of the users.

Freeboard.io is one of the websites that will be used together with the Doggy Pal Collar. There are many sensors on the collar that include a temperature sensor, heart rate monitor, accelerometer, and GPS sensor. Using a Wi-Fi module, the data collected from these various sensors will be sent to the cloud-based website dweet.io. A dashboard will be created using Freeboard.io that will collect the

sensor data from dweet.io and display them. This sensor data can be accessed from the Freeboard.io URL that anyone will be able to use. Inside the dashboard, the GPS data will be shown using a map to show the location of the collar. The temperature data will be displayed as a number value in Fahrenheit degrees. The heart rate data will be shown as a graph updating in real-time the heart rate of the dog. The accelerometer data will show the position of the dog. All this information will be on one dashboard on one page. This will make it very easy to read and understand. This sensor information will also be updating in real-time as long as the collar is within Wi-Fi range. The benefits of using the Internet of Things platform with Freeboards.io help make the Doggy Pal Collar a versatile device. The owner of the collar or a veterinarian can easily access the Freeboard.io website to monitor this information without needing to be near the Doggy Pal Collar. Furthermore, the Freeboard dashboard is very easy to customize and can easily be changed to fit the needs of the owner or veterinarian.

Dweet.io is a cloud-based website that can be used with the Internet of Things platform that is similar to twitter. This website does not need to be setup, data only needs to be sent to dweet.io to be published automatically in the cloud. Dweet.io is a web API and can easily be implemented into micro controller code with just a couple lines of code. It has many features such as real-time updates and alerts that notify the owner when data that is dweeted is outside normal parameters. Dweet.io is a free site and it's free to publish and see information that is published. Dweet.io is another website that will be used along with the Doggy Pal Collar. The collar will be sending the sensor data it receives to the Dweet.io website via Wi-Fi module. This dweet.io data will be collected by the Freeboard.io website for further manipulation before it is displayed. The dweet.io website will send out a text alert to the owner of the collar if any sensor data is abnormal such as high temperature or erratic heart rate pulses. The features of dweet.io make it a good companion website for the Internet of Things platform and allow data from the collar to be viewed in real-time by the owner or a veterinarian. Since dweet.io can be accessed from anywhere, it also makes it easy to monitor the dog. Figure 6.6.1-1 shows the flowchart of the Internet of Things subsystem for the Doggy Pal Collar.

For the final project, ThingSpeak was used for the Internet of Things platform. This website was chosen because the code was easy to setup alongside the rest of the Doggy Pal Collar components. The subsystem would be very similar however, instead of using two websites, only one website would be necessary.

Figure 6.6.1-1: Internet of Things Subsystem Flowchart

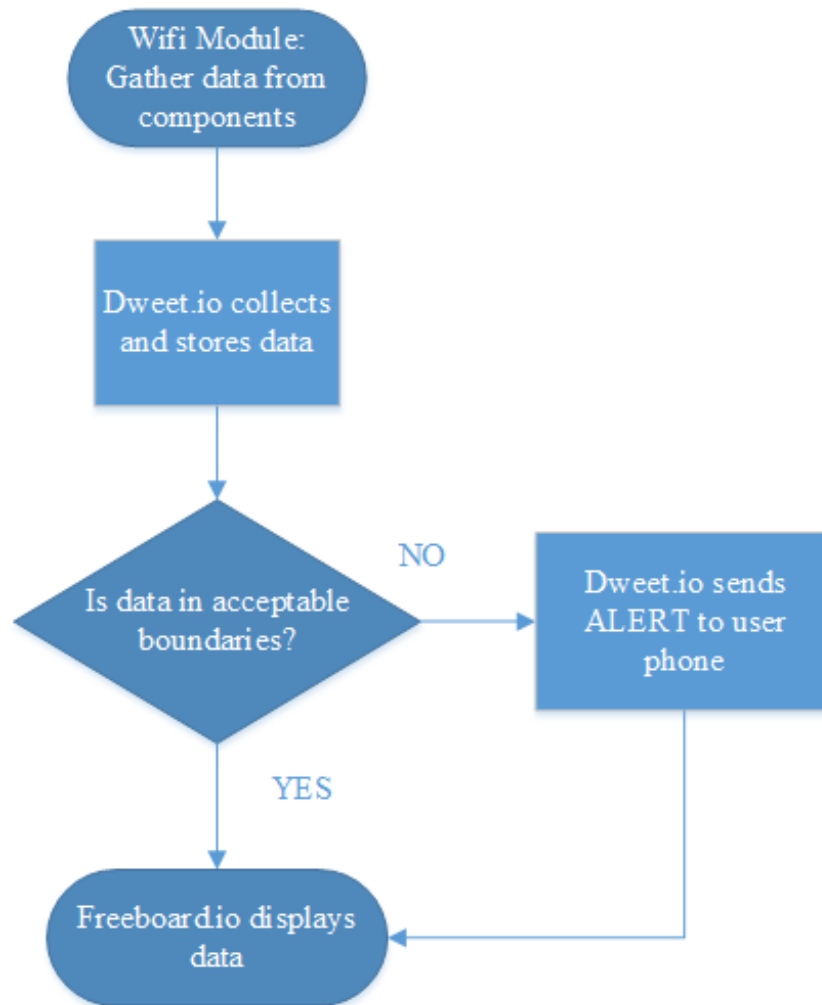

7.0 Project Prototype Construction and Coding

7.1 PCB Acquisition and BOM

Our team found there were two primary vendors in the Orlando area with very similar prices. The search online yielded these vendors but very little information regarding pricing and products. Within the design we were asked to write our design schematic in Eagle CAD. While researching other PCB vendors I found some of them used other software for submission of design. Saturn PCB Design uses their own PCB Design program called Saturn PCB Design Toolkit. With further research the team found that the Saturn PCB Design toolkit output files in Gerber format. I found that within Eagle CAD there is a function to convert your schematic/pin diagram to GERBER format. The prices for these PCB vendors were unavailable because each design exhibits its own unique cost due to the components used. For us to find a specific price for our design we had to call them up and present our PCB files with a list of the parts needed for the design. After speaking with representatives from each vendor we found the cost to be approximately 100 dollars to print our design.

Some of the standard information needed to submit a design is listed below:

- Manufacturers part numbers
- Data for all machine placed parts
- Files for PCB

7.2 PCB Design

The PCB design was created using Eagle CAD version 7.1.0 as seen in Figure 7.2-1.

Figure 7.2-1: PCB Design

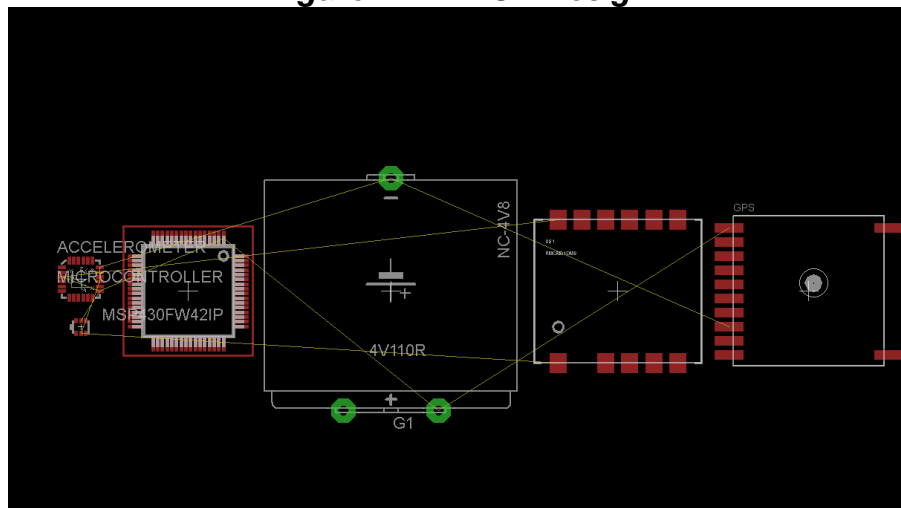

The overall design was done in a linear fashion due to the product being a collar. There were some problems integrating our devices into the design. We were required to obtain library files to import our specific components into the schematic. Initially we used components within the design that were similar to what we needed until we could get our specific library files needed. Intense research and information gathering was required to complete the schematic portion of this device because of the complexity and flexibility of Eagle Cad. It is extremely important for the collar to have a symmetrical distribution of weight on the animal so that the collar does not harm the dog or create neck issues for the animal. Some of the components on the device look large on the schematic but actually have a small weight overall so we had to take in consideration the size to weight ratio for each component. The battery overall seemed to weigh the most of every component. We wanted to keep the width of the collar at a standard width approximately the same width of the largest component as we want to keep the collar as small as possible. It is also an option for future designs to build the device on 3 separate PCB's so that it could curl easier as seen in Figure 7.2-2.

Figure 7.2-2: Three section collar design

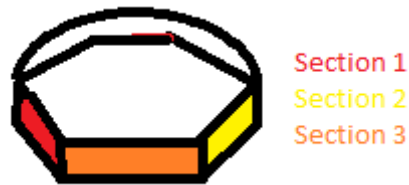

Before we created the schematic design we assembled out pin diagram as seen in Figure 7.2-3. The purpose of this diagram is to get an overall layout to see what wires run to each component. By doing this it will make it easier when doing the layered diagrams within the schematic portion of the design. Once it was complete it was much easier to oversee the layout of the design. It was much easier to know where each component needed to be connected and we could build our electrical highways much easier down the board.

Figure 7.2-3: Pin Diagram

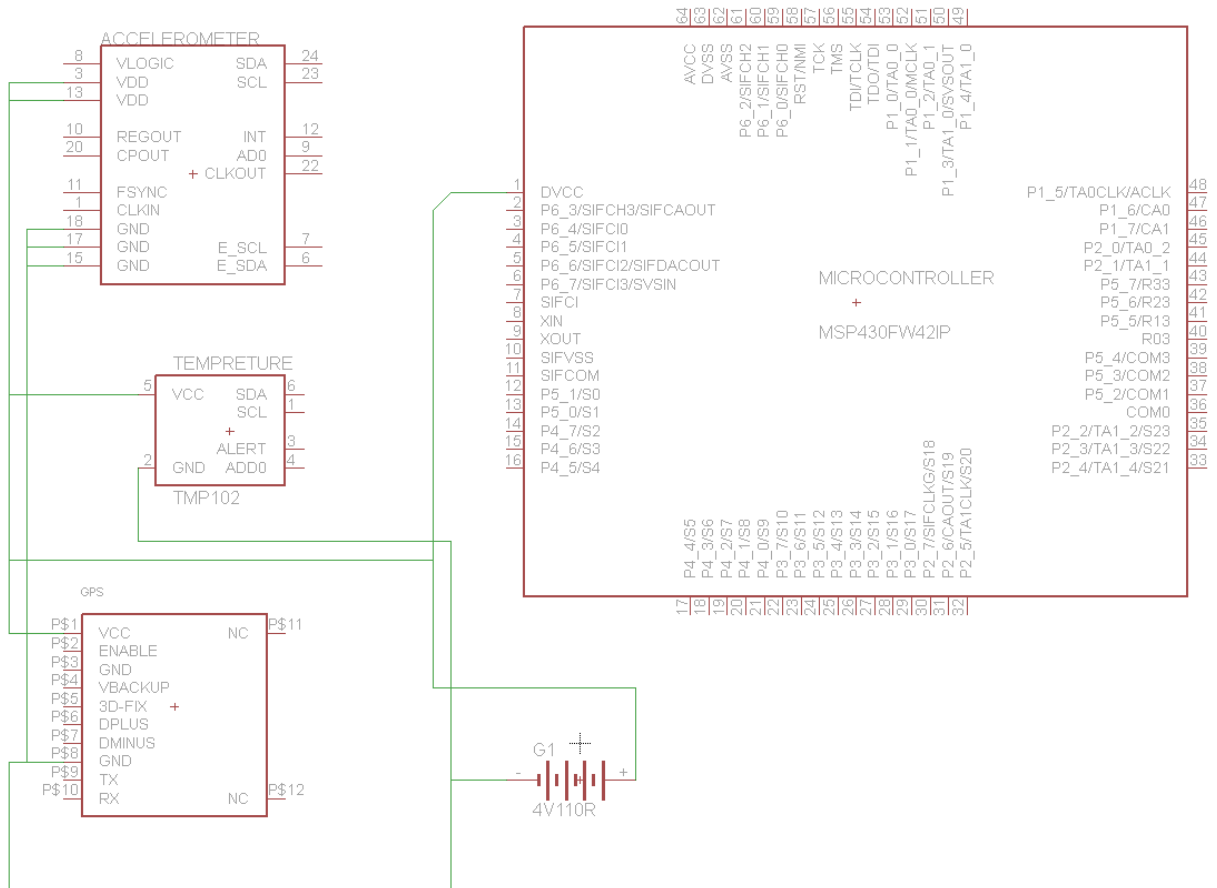

7.3 Final Programming Code Plan

Programming code will be written for each component of the Doggy Pal Collar. Since each component of the Doggy Pal Collar is independent of each other, the programming code will also be independent. This means that the components do not need data from each other to operate. This code will be written by group members for each component of the smart collar. The microcontrollers from Texas Instruments are very user friendly and programs can be written by users of all different types of programming backgrounds. The microcontroller needs to be programmed to gather data from each component of the Doggy Pal Collar and send that data via Wi-Fi to the Internet Of Things platform associated with the Doggy Pal Collar. The first component to write programming code for is the Wi-Fi module. The Wi-Fi module needs to be setup before the other components in order to send data to the Internet Of Things platform. The programming code for the Wi-Fi module needs to have certain data from the user. This data is the

password and service set identifier of the wireless network that the Doggy Pal Collar will be connecting with. Dweet.io code will also be included. This code will tell the Wi-Fi module to send data to the website dweet.io, which is a part of the Internet of Things platform for the Doggy Pal Collar.

The programming code for the GPS module will have to find the location of the dog even as the dog is moving. The programming code will be set up in a loop that constantly looks for the location of the dog. In every loop of code the data will be logged and used to map the location of the dog for easy tracking. The programming code for the temperature sensor will work similar to the GPS module. A loop will be setup to constantly check the temperature of the area the dog is located in. The programming code for the accelerometer will be separated into three pieces under one constant loop. The first part of the code will look at the X-axis position of the dog. The second part of the code will look at the Y-axis position of the dog. The third part of the code will look at the Z-axis position of the dog. The loop in this code will continually look for the position of the dog using the X-axis, Y-axis and Z-axis. The programming code for the heart rate monitor will pick up the pulse of the dog. The programming code needs to continuously loop around looking for the heart rate and picking up each major section of the pulse. These major sections are the PR interval and the QT interval. The PR interval is where the first wave is created by an electrical impulse. The QT interval is where the ventricles begin to pump and leads into the ST interval where things are electrically quiet. The code should allow the heart rate monitor to detect the electrical activity in the heart. If the electrodes of the heart rate monitor are disconnected, than the programming code should recognize this and present data that represents a flat line. Once the code for each component is completed, programming code will also be written for the Internet of Things platform associated with the Doggy Pal Collar.

Programming code for the website dweet.io will be used to setup data boundaries for the heart rate monitor. If the heart rate monitor picks up data that is outside those boundaries that will represent erratic heart rate in the dog. Dweet.io will send an alert to the owner's smartphone telling the owner to go check on their dog. To send this alert, dweet.io will need information from the user to be placed in the programming code. This information is the phone number of the user and the phone carrier email address of the user. Figure 7.3-1 shows a flowchart that represents the coding plan for the Doggy Pal Collar.

Figure 7.3-1: Final Programming Code Flowchart

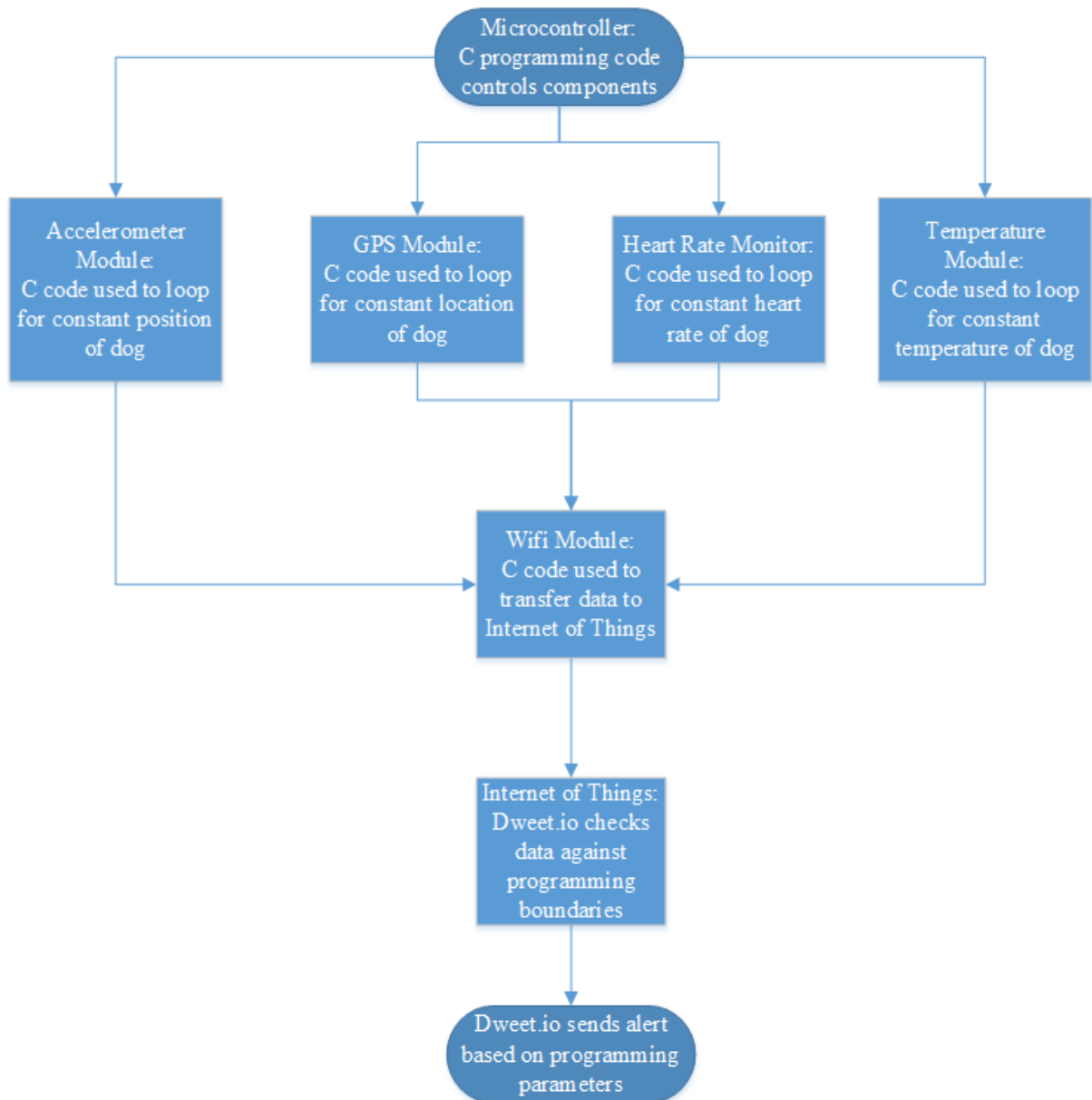

For the final project, the programming code plan was mostly the same. Some components changed types but the functions were the same and the overall goal to have data from each component be displayed on an Internet of Things website was achieved.

8.0 Project Prototype Testing

8.1 Temperature Sensor Testing

Once the smart collar has reached the prototype stage testing can begin on the TMP007 Infrared Temperature sensor. The primary characteristics of concern for the temperature sensor are its accuracy, range, sampling rate, and consistency. Each test will be repeated multiple times to ensure that the temperature sensor functions according to its specifications and meets the needs of the smart collar design.

In order to test the accuracy of the temperature sensor, another temperature measurement device which is calibrated will be used. The TMP007 and the control device will each be used to perform measurements repeatedly on a variety of objects at different temperatures. These will include water ice, cold liquid from a refrigerator, hot coffee, multiple solid objects at room temperature, and the exterior of a vehicle that has been sitting in the sun. Each device will perform each measurement three times. The temperature readings taken by the TMP007 and the control device will be recorded and compared. The results will be used to calibrate the TMP007 if necessary.

In order to test the range of the temperature sensor, objects with known temperatures will be measured at different distances. For the smart collar design, the distance will be small; less than two centimeters. To ensure the TMP007 functions properly, temperature readings will be taken on objects at zero, one, two, three, seven, and ten centimeters from the device. Each temperature measurement will be taken three times and recorded. The temperature readings from the TMP007 will be compared to the known temperatures to ensure that it is taking accurate readings at each range.

The goal of the sampling rate testing is to gauge how quickly the temperature sensor adjusts its readings as its target object's temperature changes. To perform this testing, the sensor will be taking readings on a stationary object which will be heated and cooled three times over a thirty minute interval. The readings taken by the TMP007 will be analyzed to ensure that it adjusts its output at a rate that satisfies the needs of the smart collar system.

The consistency of the temperature sensor will be tested by analyzing the results of the accuracy, range, and sampling rate testing. The temperature readings from the previous testing will be analyzed to ensure that the TMP007 is taking consistent readings over all of the tested temperature ranges with respect to time. Each measurement of an object at a known temperature should be the same each time it is taken by the TMP007 in order to be satisfactory.

8.2 Accelerometer Testing

When first testing the accelerometer it was decided to verify its functionality with another similar component. The overall characteristics to test within the accelerometer are as follows:

- Linearity
- Hysteresis
- Cross Axis Sensitivity
- Temperature Sensitivity
- Shock Response
- Bias Stability

Scale Factor Test - The scale factor test is the ratio of the sensor electrical output to mechanical input. This is done by setting a reference value to 1g so it can be verified that the device is working properly. To do this we mount our accelerometer to an automatic accelerometer calibrator. The accelerometer would be wired to this device and to verify it is working correctly it should output 1g, our reference value.

The sensitivity of the accelerometer can be measured by hooking the device up to an oscilloscope. The magnitude of the waveform can give us forward and backwards sensitivity (+g/-g).

Hysteresis Test - The accelerometer should be able to determine the changes in acceleration whether it be in the positive or negative direction. The purpose of the Hysteresis test is to determine the presence of strain/deflection on the accelerometers spring after the force has been applied then removed. When performing a Hysteresis test it should produce a linear graph while comparing the acceleration to output voltage. The more the accelerometer deviates from this linear form the less accurate the accelerometer will perform.

Linearity Test - The transfer function of the accelerometer can determine how linear the device is running. The device is mounted on a shaker and subjected to a +1g to +20g stress test at a reference frequency of 100Hz.

For the final project, the accelerometer changed types, but the same method of testing was used.

8.3 GPS Testing

The MTK3339 chip needs to work in multiple areas that the dog may go; in all the different terrains, weather conditions, and locations. Testing will center on the characteristics of this GPS that may create problems later on if they are not up to standards like time to first fix, location accuracy, signal interference, and consistency. More than one of these characteristics can be analyzed for during a

single test for some of these characteristics may emanate from the other. A program was created to test the GPS chip that works like a sonar. It will send out a signal to locate all the satellites in the area then receive and decode the response signal from the located satellites. This code is from the Adafruit website and is rightfully named “echo”.

To test the location accuracy of this GPS it would be best if the first test conducted eliminated as many interruptions as possible. This way the GPS should be able to easily obtain the decoded coordinates of the location without error and prove that it does indeed work. The best place to do this is in an open field with a cloudless sky so that there are no object in the way and the GPS has a clear view of the sky. After it is established that the GPS works the next few tests should be where a dog would presumably travel. This can mean inside a house/building, backyards, parks, cars, pathways, etc. Different weather and temperature conditions can interfere with the GPS signal as well. Therefore, these test need to not only be for different locations but also for different weather and temperature conditions like rain and snow. Some of these tests will be as simple as taking the GPS outside to test in the rain while others will be harder to achieve. Florida does not reach the temperatures need to test how the GPS will operate in cold or snowy conditions, so the GPS will have to be placed in a freezer to simulate the temperatures needed and then taken out to test how well it operates. It would be best if the GPS chip could be tested in varying locations and under varying conditions to see the limits of the GPS chip.

Single interfering is another major concern for GPS devices. Since GPS signals are generally weak even the slightest change in position can mean a fix or not. Because most of these concerns are dependent on the location of the GPS, the testing for signal interference will be similar to or conducted during the testing for location accuracy. For example, how dense can the trees in a park be before the signal is blocked? This test will determine how strong the GPS signal is and the accuracy. Locations are not the only problem with signal interference though. Many things interfere a GPS signal from everyday appliances to the buildings himself. Another example is that some window tinting for cars contains metallic components that can block GPS signal reception. The MTK3339 chip will have to be tested to determine how these common interferences will affect the performance of the GPS.

It is important to test for consistency to find out if the device will properly work over long periods of time. Each test will be repeated multiple times and under the same circumstances to keep the testing results accurate and ensure the GPS is functioning correctly. By doing this in different terrain, weather, and locations, it can be determined if the dog will safely be able to be tracked wherever he/she may go.

8.4 Battery Testing

Lithium-Ion Polymer batteries need special care and have to be charged under specific conditions, which means certain charges are needed for these batteries in order to charge safely. This sensitivity needs to be tested to find the limits that a Lithium-ion Polymer can endure before it becomes unsafe.

The battery testing will include:

- Overall battery life
- Duration of charge time
- Radiate temperature
- Impact testing
- Environmental temperature testing

Every battery will need to be replaced after a period of time and/or after and X amount of discharge/recharge. Testing the life of the battery provides the time duration that the battery can power the system before it needs to be replaced. The goal is to have a smart collar that is convenient for the owner to use, which means a healthy stretch of time between charges. To do this the Lithium-Ion Polymer battery will be discharged at the same amount it would need to for all the components in the Doggy Pal Collar to properly work; then recharged as shown in Figure 8.4-1. Batteries are rarely discharged fully according to Battery University. They state that “manufacturers often use the 80 percent depth-of-discharge (DoD) formula to rate a battery.” The 80% DoD means that 80 % of the battery's available energy is discharged with 20% still remaining in reserve. Manufacturers believe that this test is a closer representation of how batteries are commonly charged and discharged when in use by the customer. This way of testing has other benefits as well because when a battery is cycled from charged to discharged it increases the service life of the battery to not have it fully discharged. This is then repeated an X amount of times until the battery can no longer hold a charge. The results will show if the predicted time of life for the battery is accurate and for how long the battery should, under the same circumstances, last.

Figure 8.4-1: Battery Recharge Flowchart

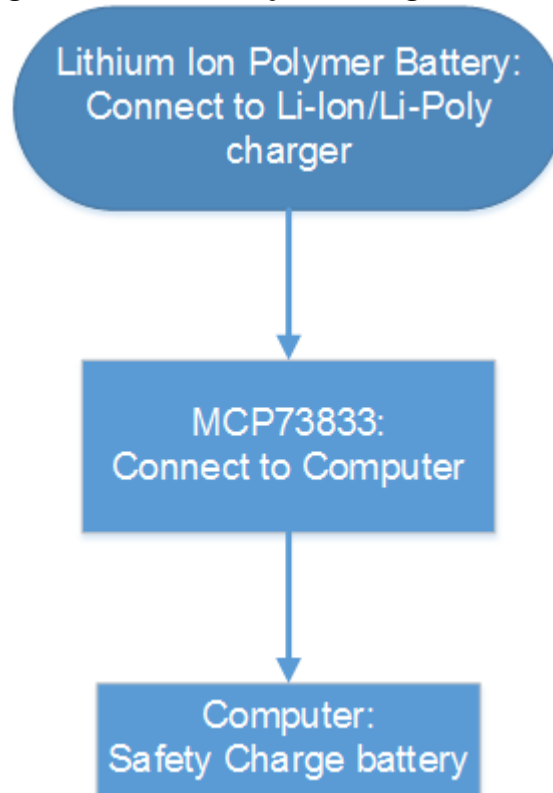

To test the amount of time it takes to fully charge can be done during the battery life test. Another requirement needed towards making the DPC convenient is a short charge time. It would be counterproductive for the battery to last a day but needs 8 hours to full charge. This test can be fulfilled during the battery life test. Each time the battery needs to be recharged the amount of time need for it to reach its full charge can be tracked and recorded. Averaging the times will result in the overall time needed to fully charge this Li-Poly battery.

The Doggy Pal Collar is designed for easy charging by allowing the charger to attach to the collar so the battery doesn't have to be removed. However, Lithium-Ion Polymer batteries emanate heat while charging. This heat needs to be measured to find the highest peak the battery can reach so the encasement can be tested to handle this peak temperature. This test can also be executed during the battery life test by measuring the temperature the battery emits and finding the peak temperature for each recharge. The highest peak time will be used to test the encasement to best test for overall safety.

Impact testing is an important factor needed for this project. An animal is an unknown element. They cannot understand that the battery in their collar may explode if it is punctured or damaged. Therefore this battery needs to be tested

to find the peak impact pressure it can endure before it becomes unstable. This test will involve using a Clamp Meter to find the breaking point of the battery and measuring the resulting pressure. Knowing this pressure point and the breaking point from the encasement will ensure this battery is well guarded from being punctured or damaged.

Again, due to the sensitivity of Lithium-Ion Polymer batteries they can explode if exposed to or not charged under the correct temperatures. This smart collar will be exposed to different weather patterns and temperatures so it needs to be tested to find the highest and lowest temperatures it can endure before it becomes unstable. According to currentresults.com the average temperature for hottest places in America can reach to over 100 degrees Fahrenheit. They also state that the average temperature in the winter is “just above freezing” at 33.2 degrees Fahrenheit. The Doggy Pal Collar needs to be tested for these temperatures to find the limit it can withstand. To do this the battery may need to be heated and cooled, to see if it can withstand these temperatures. Every scenario that a dog may find itself in need to be taken under consideration when testing this smart collar.

8.5 Heart Rate Monitor Testing

Testing the heart rate monitor system will be different compared to the testing of other components for the Doggy Pal Collar. The testing of the heart rate monitor cannot be done on humans or animals. This limits the different ways available to test the heart rate monitor because the heart rate monitor needs a heartbeat to read data from. The GPS module, accelerometer, Wi-Fi module and temperature sensor do not require animals or humans to be tested on. In order to get around these limitations, a heart rate will be simulated electronically in order to test the heart rate monitor. The heart rate monitor will be tested by group members. Specially trained individuals will not be required for testing the heart rate monitor. The heart rate monitor works on the idea of electrocardiography. This is the procedure of measuring the electrical activity in the heart using electrodes that are attached to the body. An external component that is not part of the Doggy Pal Collar will be necessary for testing the heart rate monitor. This component is a phone application called Medsby ECG Simulator. This phone application simulates a real-time analog electrocardiogram signal through the sound card in the phone. Figure 8.5-1 shows a picture of the Medsby ECG Simulator application running on a project member’s phone. An audio jack will be placed in the headphone socket of the phone. A real-time electrocardiogram signal input can be generated by connecting the ground pin of the audio jack and the speaker output pin of the audio jack to any device you want to send the electrocardiogram signal to, like an oscilloscope or heart rate monitor. Figure 8.5-2 shows an example of the Medsby ECG Simulator connected to an oscilloscope. The Medsby ECG Simulator also allows for different heart rate speeds to test different amplitudes of the electrocardiogram signal.

Figure 8.5-1: Medsby ECG Simulator Application

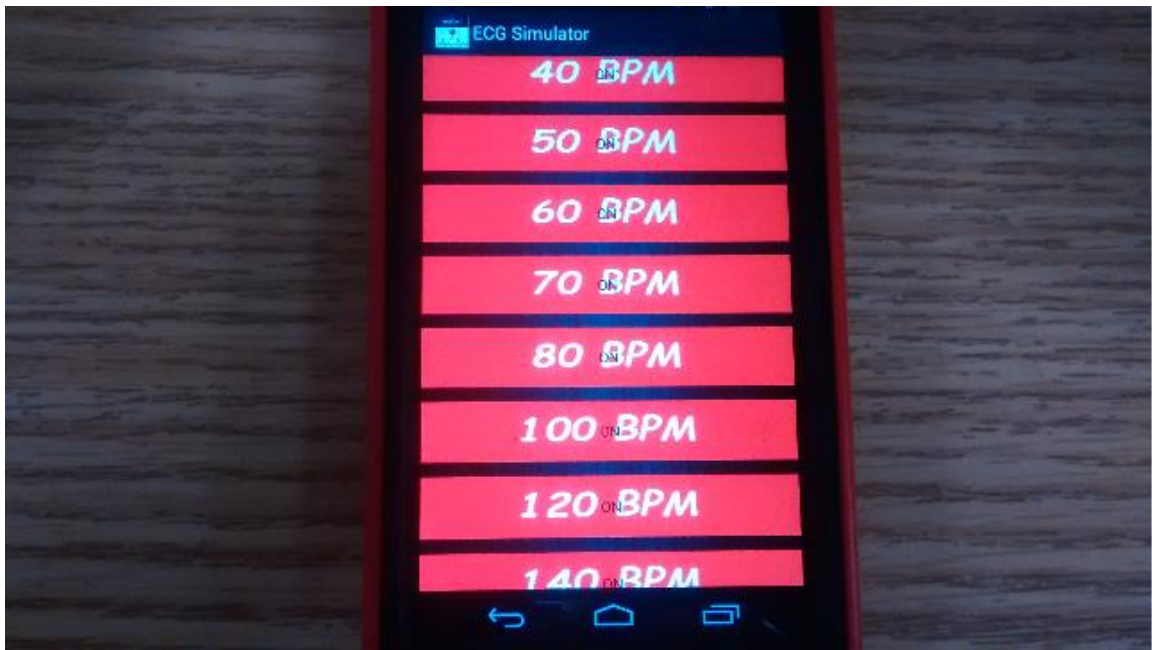
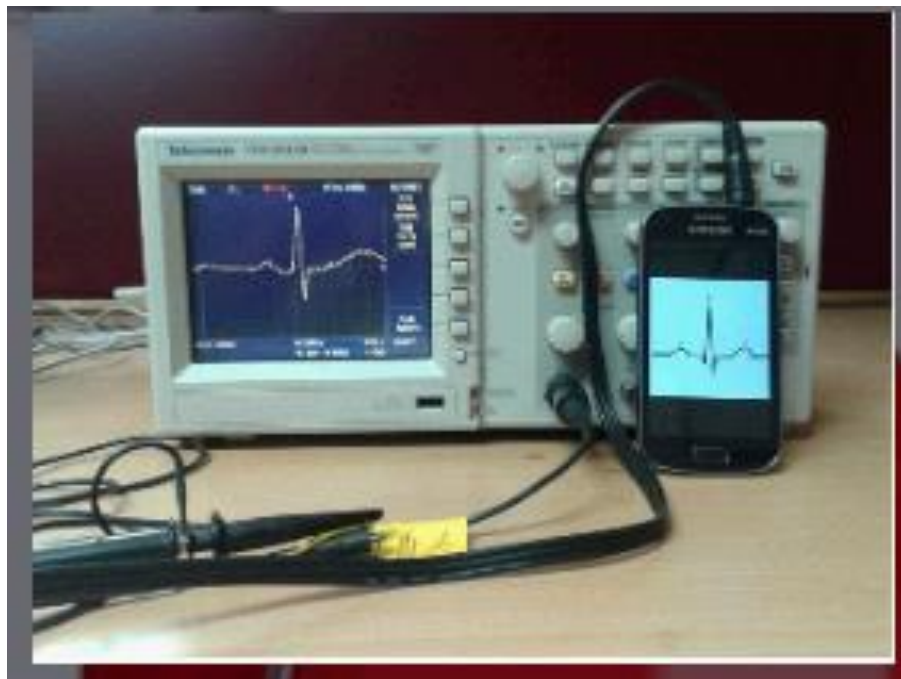

Figure 8.5-2: Example of Medsby Simulator Connected To Oscilloscope (Courtesy of Medsby)



The heart rate monitor will connect to the Medsby ECG Simulator by connecting the electrodes of the heart rate monitor to the ground pin and speaker pin of the audio jack that is connected to the phone with the Medsby ECG Simulator. Once the connection is made the Medsby ECG Simulator will simulate an electrocardiogram signal at 40 beats per minute for testing the heart rate monitor. The heart rate monitor will be tested at different heart rate signals that simulate different activities for a dog. The normal dog at rest has a heart rate of 60 to 160 beats per minute. The Medsby ECG Simulator can go as high as 180 beats per minute and as low as 40 beats per minute. Starting at 40 beats per minute, the Medsby ECG Simulator will be increased by 20 beats per minute for each test of the heart rate monitor up to 180 beats per minute to make sure the heart rate monitor can pick up a wide range of heart rate signals. The heart rate monitor will also be tested for flatline readings. This will be done by disconnecting the Medsby ECG Simulator from the heart rate monitor. When this is done the heart rate monitor should flatline and show no activity on its graph. Figure 8.5-3 shows a flowchart of the heart rate monitor testing procedure.

The component that needs to be tested first for the Doggy Pal Collar is the Wi-Fi module. The Wi-Fi module will be sending the heart rate data to the Internet of Things platform, therefore before the heart rate monitor can be tested the Wi-Fi module will be setup first. Every other component of the Doggy Pal Collar is independent enough that each component can be tested at any time in any order. These components work on their own and do not communicate any data between each other, they only send their data to the Wi-Fi module. The heart rate monitor will be tested in various areas that a dog would normally go to in an average house. These areas include the back yard, front yard, bathroom, bedroom, under a bed, and on a table. No matter what location the heart rate monitor is in, the data should be sent to the Wi-Fi module without any connection errors. Any connection errors could cause the heart rate graph to be displayed wrong and show inaccurate data. When the heart rate monitor picks up the electrocardiogram signal it will be sent to the microcontroller. The programming code inside the microcontroller will take the electrocardiogram signal and send that data to the Internet of Things platform via the Wi-Fi module. The Internet of Things platform used for the Doggy Pal Collar are two websites called dweet.io and freeboard.io. These two websites will be storing and displaying the heart rate monitor data in a graph form for the user to see.

First the electrocardiogram signal will be sent to dweet.io and stored on that website. Freeboard.io will collect the electrocardiogram data from dweet.io and display the data using a dashboard on the freeboard.io website. The dashboard will be setup to display the electrocardiogram data in graphical form in real-time. With this setup, when the heart rate monitor picks up rapidly changing heart rate signals the data should change in real-time on the freeboard.io website. This will be tested by rapidly changing the heart rate beats per minute on the Medsby ECG Simulator. It will also be tested by sending a flatline signal from the heart rate monitor to the Internet of Things platform. A user should be able to open a computer, smartphone or tablet and be able to access the heart rate monitor data

from freeboard.io. Special boundaries will be setup using programming code for the microcontroller and the dweet.io website. These boundaries will include rapidly changing heart rate data, very low heart rate data and very high heart rate data. If dweet.io picks up this type of data it will trigger an alert from the website. This alert will be sent to the user's smartphone. This alert will tell the user that something could be wrong with the dog and that the user should go check on the dog immediately. If the heart rate monitor data that is sent to dweet.io is within acceptable boundaries, then no alert will be issued and instead the data will wait to be collected by freeboard.io.

Figure 8.5-3: Heart rate monitor and Internet of Things flowchart

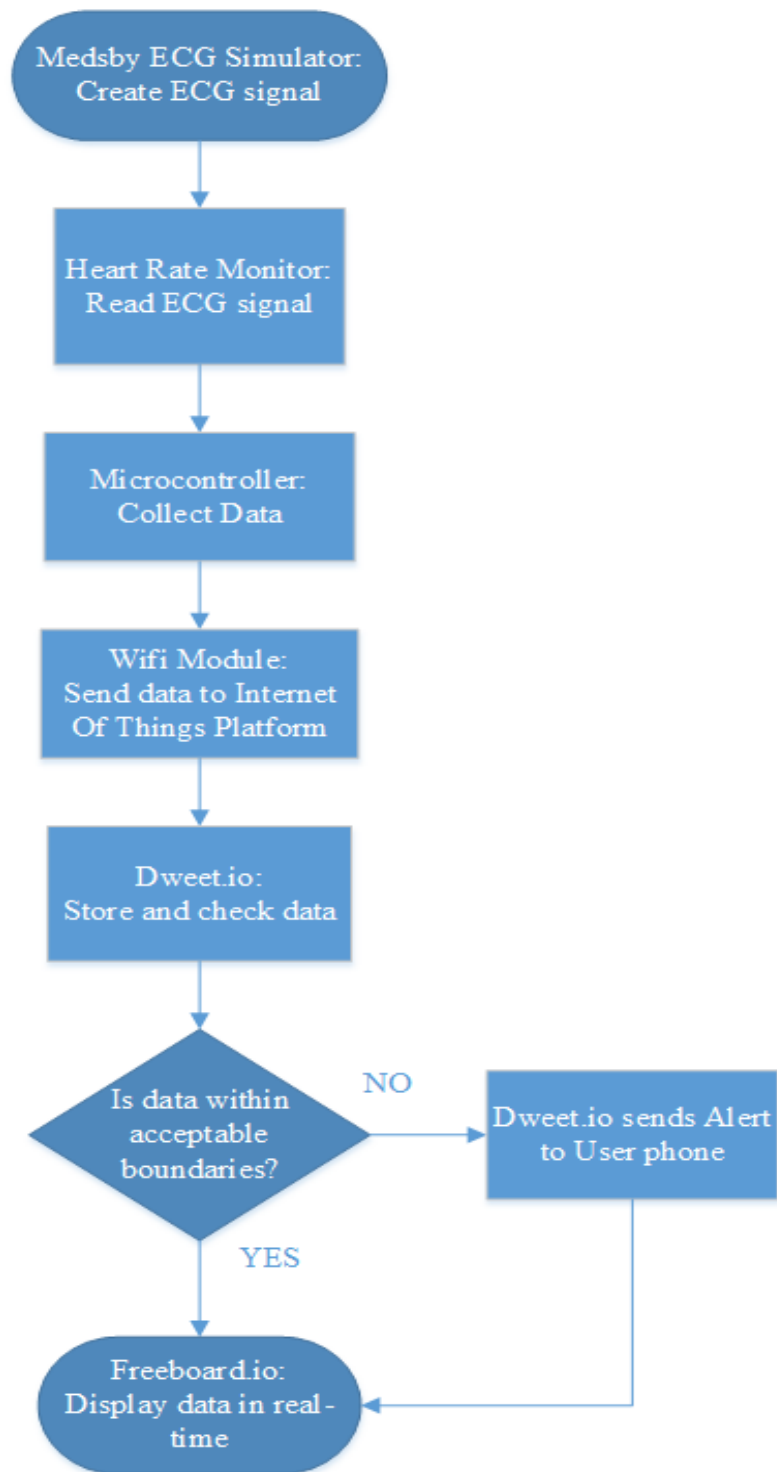

For the final project, the heart rate monitor changed to a different type, but the testing was the same.

8.6 Wi-Fi Testing

When testing the Wi-Fi the design needed to set the specifications of the device for our specific microcontroller and verify that everything is working properly. The device the team choose to use is the TI CC3100 Simple Link Wi-Fi Adapter. The flowchart for the internal components can be seen in Figure 8.6-1

Figure 8.6-1: Internal Flow Diagram of CC3100

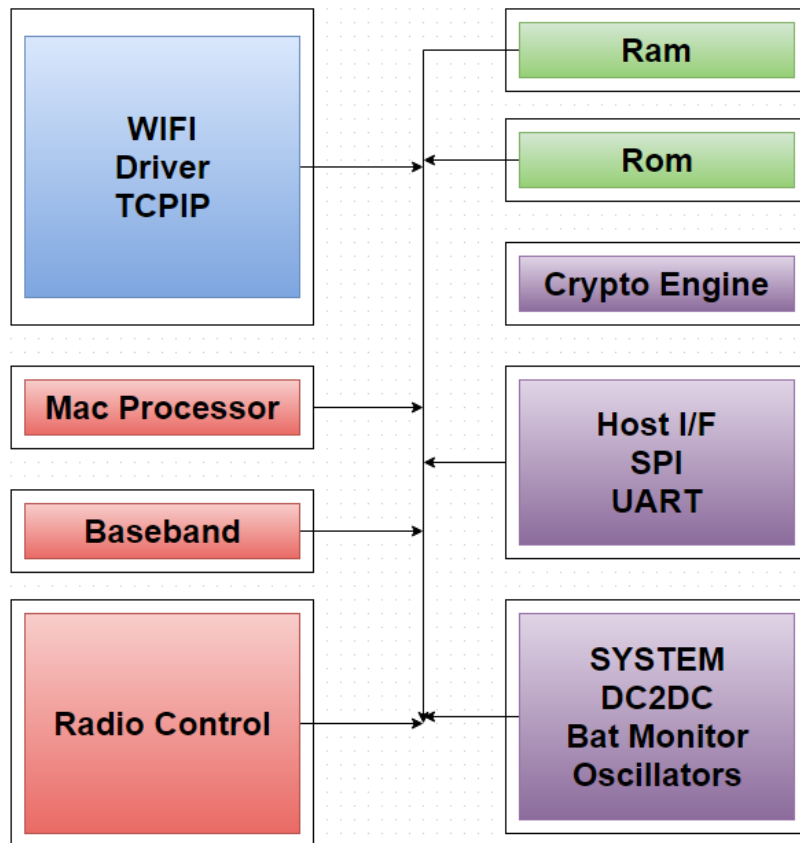

It was decided analyze the CC3100 as our Wi-Fi Adapter because of its versatility, size, weight, and specifications. Although these are general reasons, this device goes far beyond the needed requirements. This device can connect to just about any microcontroller that is 8, 16 or 32 bit. Below are some of the standard specifications for this. This is a Wi-Fi Certified chip. The internal Clock runs at 32.768 KHz with a startup time of 250ms.

- Internal clock is 32.768 KHz
- Initialization Time is 250 ms
- Wi-Fi certified chip
- 802.11 b/g/n Radio, Baseband, and Medium Access Control (MAC)
- Interfaces with 8, 16 and 32 bit MCU's

- Integrated DC/DC supply voltage
- Operates from 2.1V to 3.6V
- Pre Regulated 1.85V
- Low voltage deep sleep mode runs at 115 Microamps.
- Clock source is a 40 MHz crystal with an internal oscillator
- Ambient temperature range of -40 to 85 Celsius

The pin diagram layout consists of 64 pins in which about 50 of them are used as shown in Figure 8.6 -2 and Table 8.6 - 1.

Figure 8.6 -2: Wi-Fi Pin Diagram (Courtesy of Texas Instruments)

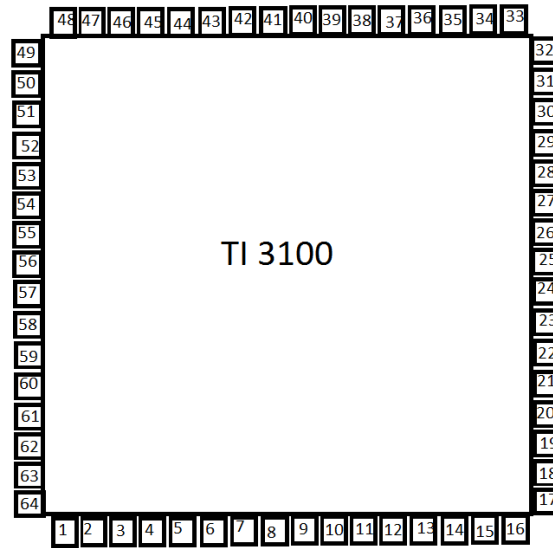

Table 8.6 - 1 Pin Diagram Layout:

1	unused
2	Hibernate Signal
3	Reserved
4	Forced AP Mode
5	Host interface for SPI Clock
6	Host interface for Data Input
7	Host interface for Data Output
8	Host interface for Chip Select
9	Digital Core power supply 1.2 V

10	I/O Supply
11	Serial Flash Interface for SPI Clock
12	Serial Flash Interface Data out
13	Serial Flash Interface Data In
14	Serial Flash Interface for SPI Chip Select
15	Interrupt Output for active high
16	Unused
17	Unused
18	Unused
19	Connect 100k pull down to ground
20	Enable Signal

21	Enable Signal for external TCXO
22	Connect to WLAN
23	Connect to WLAN
24	Internal PLL Power Supply 1.4V
25	Input to internal LDO
26	Unused
27	Unused
28	Unused
29	Reserved
30	Reserved
31	2.4GHz RF TX/RX
32	Reset for input device
33	Power supply for the RF Power Amplifier
34	100K Pulldown to ground

35	100K Pulldown to ground
36	Input to internal LDO
37	Power Supply for the DC-DC converter
38	Analog DC-DC Converter
39	PA DC-DC Converter input supply
40	PA DC-DC Converter switch output

41	PA DC-DC Converter switch output
42	PA DC-DC Converter output
43	PA DC-DC Converter switch output
44	Power supply input for the digital DC Converter
45	Analog2 DC-DC Converter
46	Analog2 DC-DC Converter switch output
47	Analog2 Power Supply Input
48	Analog1 Power Supply Input
49	Power Supply for the Internal Ram
50	UART Host Interface
51	32.768 kHz XTAL_N/external CMOS Clock input
52	32.768 kHz XTAL_N/100k external clock
53	Unused
54	I/O Power Supply
55	UART Host interface
56	Digital power supply (1.2V)
57	UART Host Interface
58	Test Signal
59	Test Signal

60	Test Signal
61	UART Host Interface
62	Test Signal
63	Leave Unconnected
64	Leave Unconnected
65	Ground

For the final project, a bluetooth device was used instead of wifi, however, the testing was the same.

8.7 Collar Stress Test

When the testing first began we had to determine which materials we would use for the collar. It was decided by the team to use ABS or Acrylonitrile butadiene styrene for our design. This material closely resembles the consistency of Lego blocks. The most notable properties of ABS is their resistance and toughness. Structural modifications can be made to this material to increase its resistance to strain and stress. ABS creates about 3 layers per 1 mm and can be purchased in many different color options The minimum thickness for ABS is approximately 1mm. Aside from its physical properties this material has a high resistance to temperature. It is capable of being tolerant to temperature from -20 to 80 Celsius. The final step of the molding process involves molding the product at high heat. There are many different ways of processing this material, our strategy is to use a 3d printer and mold it ourselves. This also gives up the option of later applications of creating different sizes for the animal. The ABS material is nontoxic to animals making it safe. After the collar was molded we used a three point stress test to analyze the strength of the material. The team found it met the expectations of the design.

The University of Central Florida informed the group that due to a shortage of plastic used for the 3D printer, neither of the Auto Cad designs could be printed. Because of this the new plan was too hand make a collar for the Doggy Pal Collar. For this DIY project an 11x14x.093 (LxWxH) inch, clear plastic sheet was used to quickly make a box shape collar. Using UCF's laser cutter to accurately cut the six sides need for the box, they were then painted and glued together with silicone and enforced with brackets. The brackets were used to secure each of the four walls to the bottom plastic. A hinge was used to attach the top cover to one of the walls as to open and close the box easily. Because this box was handmade there was no section created for the collar to pass through as can be

seen in both figures above. Therefore the collar was screwed to the side of the box with the temperature sensor and pulse sensor as they need to be placed on the side closest to the dog as seen in Figures 8.7 – 3, 4 and 5 below.

Figure 8.7 – 3: Final Collar Design 1



Figure 8.7 – 4: Final Collar Design 2



Figure 8.7 – 5: Final Collar Design 3



9.0 Project Plan

9.1 Division of Work Responsibility

The work was divided 4 ways. Each member had responsibility of two separate components of the design as seen in Figure 9.1-1. Stephanie was assigned to the Power and GPS systems. Bryon was assigned to the Temperature System and MCU. Dustin was assigned to the accelerometer and the Wireless Communication, and Steven was assigned to the Heart Rate Monitor and Data Analysis. As the team began working and assembling the different components each member worked closely together. When testing specific components the group found that no single person could work on one specific component as it was required for at least 2 people to focus on each component. For example Steven and Bryon had to constantly work together as Steven was assigned to programming the system and Bryon was assigned to the MCU. Stephanie and Dustin were both assigned to components of the design so they had to be constantly in contact with Steven to properly program and configure their particular components. Stephanie initially had to communicate with everyone on the team until the group finalized our electrical schematic. The entire team had to work together to get the best possible wiring diagram to ensure the most efficient electrical model.

The project was constantly changing and evolving, some parts of the project that seemed short turned out to be long, while some parts that seemed long turned out to be short. During the weekly meetings, group members would update each other on the progress of their parts of the project as well as discuss what needed to be completed next. These meetings were also a good time to work out any problems the group members might have run into while working. As each member continued to go deeper into their work, good communication and good project management were key for the continued success of the project.

Figure 9.1-1: Block Diagram

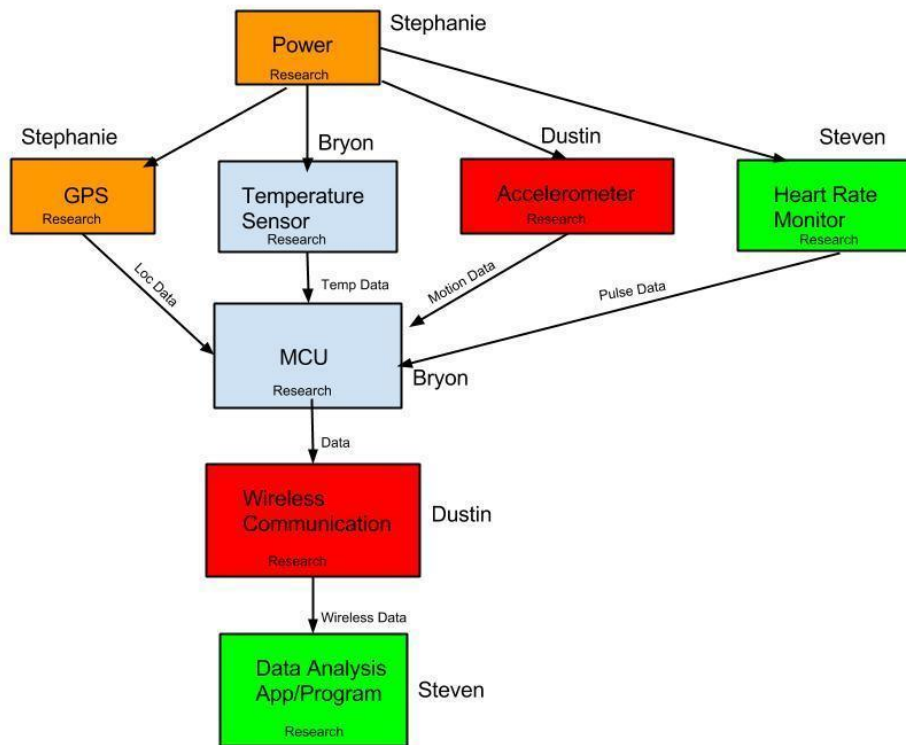

9.2 Milestones

The duration of Senior Design I is used for the developing and research stages of the design process. The team also used this semester to acquire project parts to test in the coming semester. In the start of Senior Design I the team's first step was to brainstorm ideas to develop for the Senior Design project. During a team meeting the idea for the Doggy Pal Collar was decided, based on each member's individual skills and passions, and the design process began. In Senior Design Bootcamp it was explained how the human brain cannot envision a new design idea once a suggestion has been placed. To overcome this presuppose problem it was said that each member should come up with at least 30 different ideas designs. The magic number 30 is when the minds stops reproducing the same concepts and starts creating something new. In this design stage the team each individual came up with 30 different designs for a heart monitoring dog collar. Next the team researched the parts that would be needed to create the smart collar and redesigning where necessary. This can be seen in the Timeline Graph 9.2 - 1 below:

Figure 9.2-1: Timeline Graph of Senior Design I

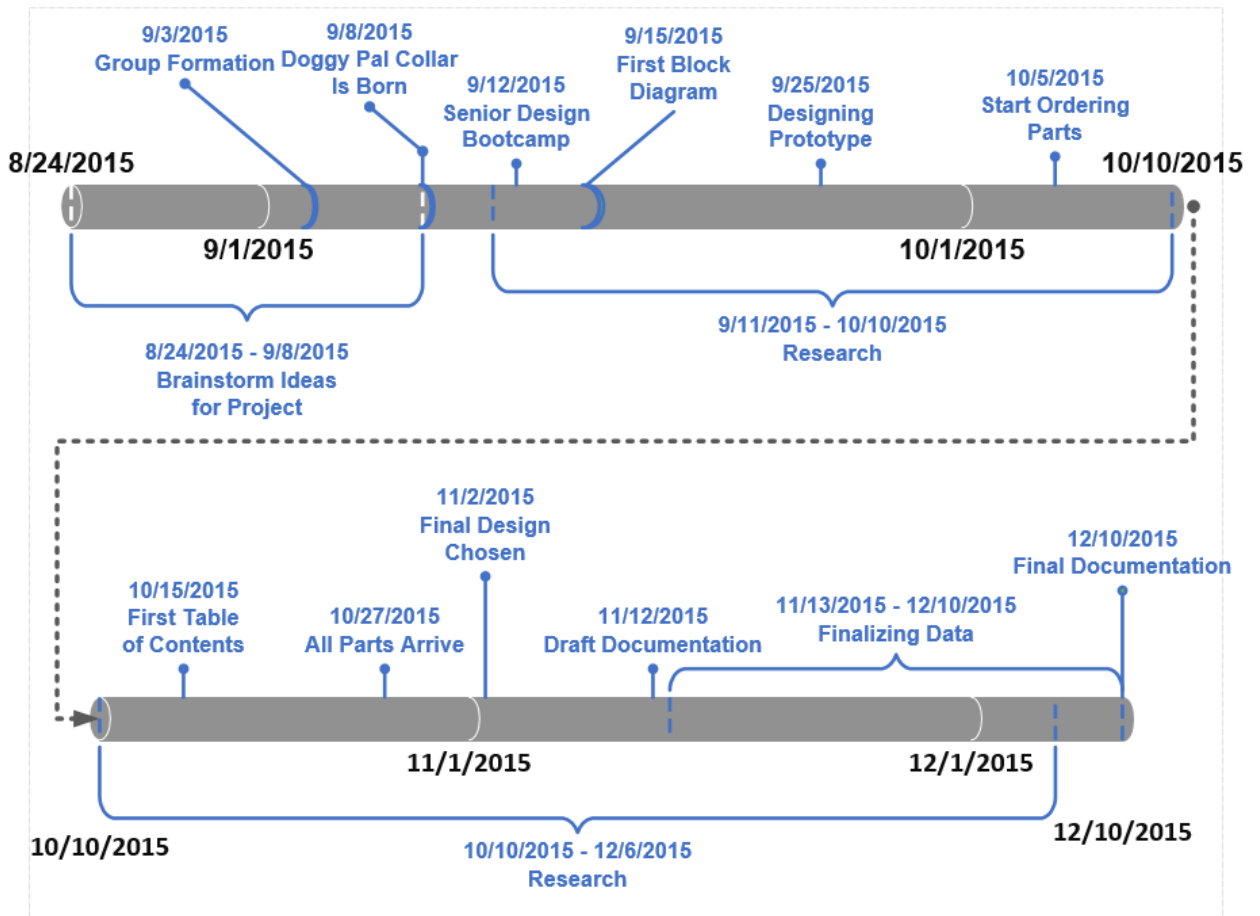

The duration for Senior Design II is used for the prototyping, testing, and final development stages. The team plans to test all the components individually then again when all the components are connected in one system. Testing the prototype to make sure it functions correctly for a dog will be a challenge. With animal and human testing disallowed the testing stage needed a brainstorming stage of its own to develop unique ways to overcome this restriction. The collar itself needs to be developed and tested to make sure it meets all its requirements. This semester will also be used for any redesigning that may be needed do to component and/or design failures. Final the completed project will be presented and given to our team member for his dog to use. This can be seen in the Timeline Graph 9.2 - 2 below:

Figure 9.2-2: Senior Design II

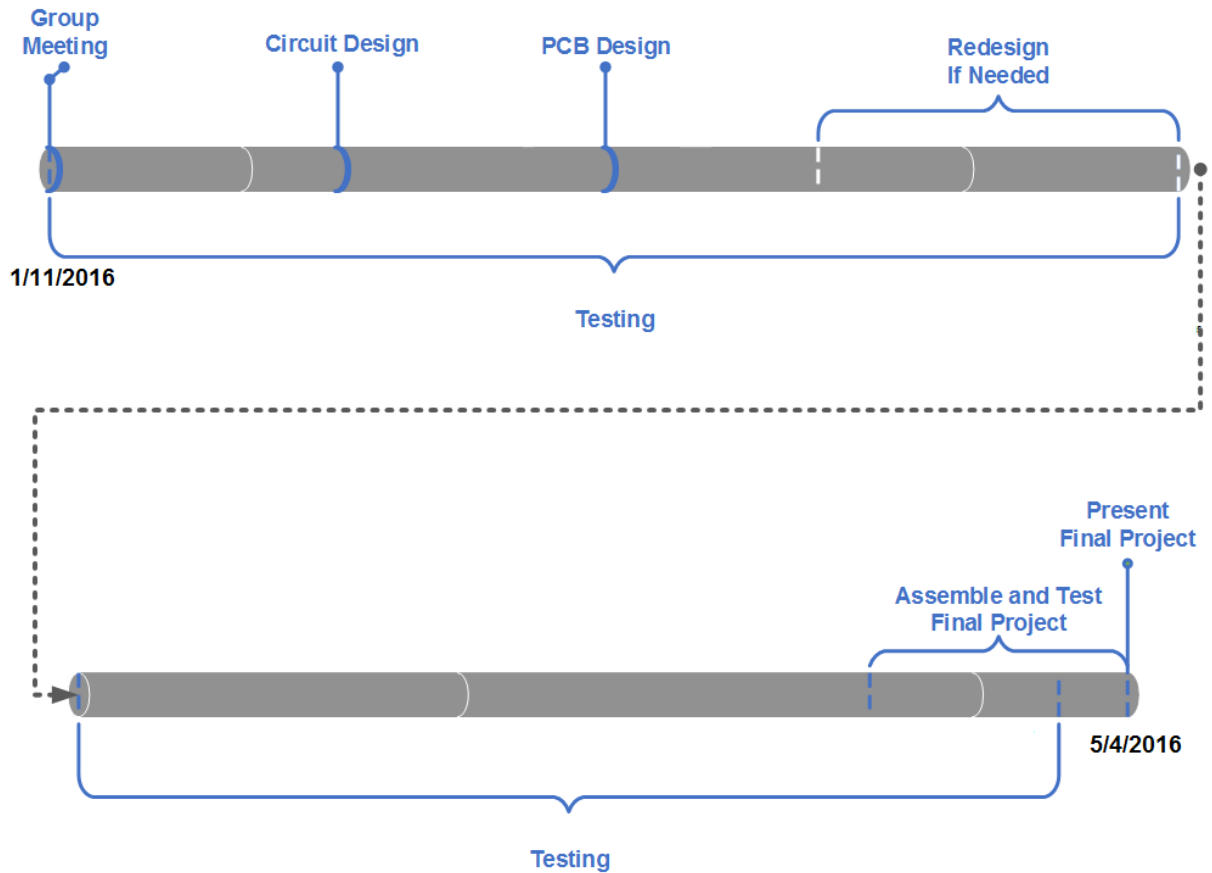

9.3 Budget

One goal for the Doggy Pal Collar was to keep the budget as low as possible. The maximum spending amount goal for the Doggy Pal Collar was \$100. When doing research on similar products a common trend among them was the high price point. Dog collars that only had one feature such as temperature sensing or GPS tracking were expensive, while collars that had multiple features such as heart rate monitoring and GPS tracking were very expensive. The conclusion was quickly reached that these type of smart collars were being treated like specialty collars for hardcore animal lovers. The idea seemed to be that the people who were animal lovers would gladly pay a high price for a smart collar because they loved their animals so much and would pay any price to keep their animals safe. In turn, this high price point turned off the average animal owner who did not have the amount of money necessary to invest in a smart collar. The Doggy Pal Collar was envisioned as a smart collar that would be low cost and have a good quality design. This collar would not be a cheap knock off with

questionable material. Instead, it would have multiple features that included GPS tracking, heart rate monitoring, position tracking and temperature sensing with a long lasting battery power and quality design and comfort. The components would have to have a reasonable cost to keep within the budget of \$100 while also meeting the specifications set for the Doggy Pal Collar. This budget of \$100 was selected because it represents a good cutoff point for the average animal owner. With all the features that will be included in the Doggy Pal Collar, the price point of \$100 will be very cheap compared to what the Doggy Pal Collar can do.

Therefore, it was important that the parts selected and the prototype built would be able to meet the low cost goal but still maintain the high quality goal. Many different parts were discussed and researched, but after refining the objectives and goals of the Doggy Pal Collar, certain parts began to stand out. Table 9.3-1 shows the parts chosen for the prototype Doggy Pal Collar. These parts were determined to be high in quality but still cheap enough to provide a low cost alternative to the current market of smart dog collars. The total price of the Doggy Pal prototype collar is within the team's acceptable goal of only spending around \$100. Surprisingly, the most expensive component was the GPS unit. This is most likely because the GPS unit comes with a lot of extra features. If the budget begins to balloon out of control, a cheaper GPS unit might be selected that has less features. The total cost of the prototype Doggy Pal Collar is reasonable. However, it is possible that the final design might go over budget, especially when the 3D casing for the components is taken into account. Because the goal was to create a smart collar that would be cheaper than the competition, reaching a cost of around \$200 will defeat one of the objectives for this project. The budget will be closely watched for the final design and more sacrifices for cheaper components and cheaper design materials might have to be made to stay within an acceptable budget.

Table 9.3-1: Prototype Parts List and Cost

Component	Prototype Items	Vendor	Cost
Heart rate monitor	AD8232	Digi-Key	\$3.53
Temperature sensor	TMP007	Digi-Key	\$6.40
Accelerometer	MPU-9255	InvenSense	\$7.22
GPS	MTK3339	Adafruit	\$29.95
Wi-Fi	CC3100	Digi-Key	\$14.07
Battery	Lithium Ion Polymer Battery 3.7v 2500 mAh	Adafruit	\$14.95
Microcontroller	TMP4C123GH6PM	Mouser Electronics	\$11.42
Total			\$87.54

For the final project, the budget increased and some parts changed. This went against the goal of having a low costing collar, however the Doggy Pal Collar was still competitive even at the new price for the parts.

9.4 Finances

The finances for the Doggy Pal Collar will be split between the members of the team. At a budget of \$100, the Doggy Pal Collar is very cost efficient for both the teammates and any animal lovers who need a reliable smart collar at a reasonable price. A veterinarian one of the team members know could also help finance the project with a \$100 donation. The veterinarian was interested in the Doggy Pal Collar and the possibilities the collar has. This \$100 donation will help greatly with any unexpected costs that occur during the development of the Doggy Pal Collar. Many of the components that are being used in the prototype stage of development are from Texas Instruments. This company allows for some components to be sampled for free and delivered with free shipping. The team is taking advantage of this opportunity and getting free samples of different components to test and try. Texas Instruments also allows for multiple free samples of the same component for certain products it sells. Therefore, many

backup pieces have been acquired free of charge. These backup pieces can be used in the event that any main components break.

With of all these opportunities that the team is taking advantage of, the finances for the Doggy Pal Collar so far have been very minimal. However, the team still wants to keep the components cheap enough to meet the \$100 budget. Table 9.4-1 shows every component that has been obtained during work on the Doggy Pal Collar that will not be used in the project. These components are different than the parts used in Table 9.3-1, from section 9.3 Budget, which will be used for the prototype design and possibly used for the final design. The parts in Table 9.4-1 will not be used for anything and can be considered as wasted components. These parts were acquired during the research phase of the project when many different parts were being looked at. That has caused these parts to no longer be useful for the Doggy Pal Collar and the money spent on them was wasted. These parts would not be considered as unexpected costs because these components were obtained with a purpose of being used, whereas an unexpected cost would occur from something unexpected and unplanned happening, like a component burning or breaking. The team simply chose parts too soon before all the necessary research and specifications for the Doggy Pal Collar was completed.

Table 9.4-1: Wasted Project Parts

Component Name	Vendor	Price
HUZZAH ESP8266 Breakout	Adafruit	\$9.95
Triple-Axis Accelerometer	Adafruit	\$7.95
DHT11 Temperature and Humidity Sensor	Adafruit	\$5.00
Nokia 5110/3310 LCD Screen	Adafruit	\$10.00
Total:		\$32.90

The final project has no sponsors and with a change in components used in the smart collar, the final cost was split between the members as shown below.

Figure 9.4 – 1: Final Costs

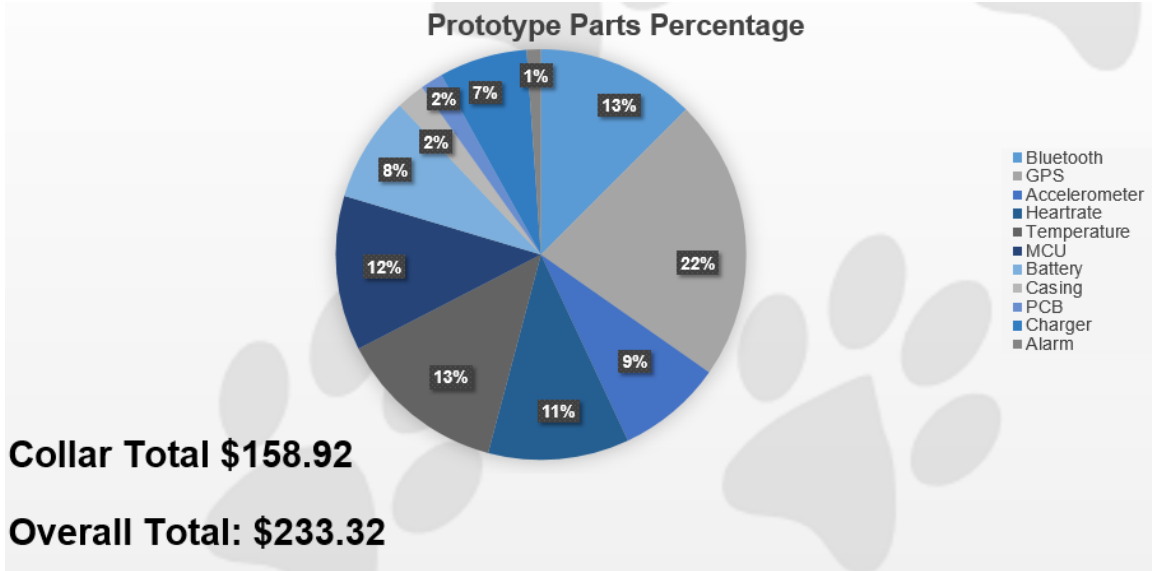

10.0 Project Operation

First the user must download and install the Processing program from processing.org. The program must be installed on a personal computer that has Bluetooth connectivity and an internet connection. The program may be installed to any directory, on any compatible operating system.

Next the Bluetooth connectivity must be enabled on the computer to which Processing has been installed. Once the computer's Bluetooth module is on, turn on the Doggy Pal Collar by flipping the switch found on its side. Once the collar is turned on, its Bluetooth module will power up and become available for pairing. The collar's Bluetooth module will identify itself as "Adafruit EZ-link." Navigate to the Bluetooth settings menu on the computer with Processing installed (host computer), and pair with the collar. Pairing may take a minute or so.

Next, a terminal program will be needed in order to identify the correct COM port. The Bluetooth module on the collar will open two COM ports for communication with the host computer, and the user needs to determine which one is the proper one for Processing to use. The recommended terminal program for this device is the serial monitor in the Arduino IDE program. Arduino IDE is available for download at Arduino.cc, in the downloads section. Arduino IDE may be installed to any directory the user desires. Once Arduino IDE is installed, the user should run the program. The user should go to the Tools dropdown menu in the toolbar at the top of the IDE window. In the tools dropdown, the user will see the option to select from available COM ports, labelled as "Port: ." If the host computer is properly paired with the Doggy Pal Collar Bluetooth module, and the Doggy Pal Collar is powered on, then the user will see at least two COM ports listed under this menu. In order to determine whether a particular COM port is receiving data from the collar's Bluetooth module, the user must choose that COM port, and then open the serial monitor within the Arduino IDE. The option to open the serial monitor is located under the Tools dropdown menu. After opening the serial monitor, the user should select baud rate of 115200. The baud rate selection dropdown is located at the bottom right of the serial monitor window. Next the user should wait 20 to 30 seconds for Bluetooth configuration. If the serial

monitor does not display any data after 30 seconds, the user should try another COM port. Once the correct COM port is open in the serial monitor, the collar will print data continuously after the configuration period. Once the user has verified the correct COM port, the user should take note of its number, and close the serial monitor and the Arduino IDE program.

Next, the user should use the Processing program to open the .pde file that is supplied with the Doggy Pal Collar. The Processing window will now show the .pde source code which is used to gather data from the collar and transmit it to the IOT platform. The user must alter the “COM ##” portion of line 18 to match the COM port number that was noted previously. If the change to the COM name in the code is saved, this step only needs to be run for initial configuration.

Once the COM port name in the .pde file is changed to reflect the proper port, the user should select Sketch from the Processing program toolbar, and then select Run from the dropdown menu. The sketch will begin to run, and will continue to gather data from the collar as long as the collar is on and within range, until the Stop button is clicked, or the program is closed. The Thingspeak channel for the user’s Doggy Pal Collar device will be continuously updated as long as the collar is on and within range, and the Processing program is running the .pde file. The user may check the collar data from any device that can access the Thingspeak website, from any location. Data will be updated in 15 second intervals.

To turn off the Doggy Pal Collar, simply turn the switch to the off position and either press the Stop button in the Processing program or exit the program. The Doggy Pal Collar does not need to be reconfigured after powering down. When it is powered back on, it will be ready to connect and resume broadcasting data. The .pde file will need to be re-run in the Processing program each time the collar is powered down, or the connection is lost.

To recharge the lithium ion battery, open the lid of the housing and plug into a USB connection. Do not recharge the collar while it is being used.

10.1 Troubleshooting the Doggy Pal Collar

The collar won't power on.

Try recharging the battery.

There is no data being transmitted.

Make sure that you have entered the correct COM port number in the Processing .pde file. Make sure that your computer is paired with the collar's Bluetooth module. To check whether the problem is with Processing or the collar hardware, connect with a terminal program such as Arduino IDE's serial monitor and verify whether data is being transmitted by the collar.

The collar doesn't show up for Bluetooth pairing.

Verify that the host computer's Bluetooth is enabled. Make sure that the collar is as close as possible to the host computer while pairing.

When I run the .pde file in Processing, I get a connection error.

Verify that your host computer is paired with the collar. Exiting Processing, stopping the sketch, or powering down the collar all cause a connection loss. Make sure to wait at least 30 seconds after a connection loss before attempting to connect again. Some operating systems "hold on" to the Bluetooth COM port for too long and cause this error.

I am getting an error when I run the .pde file in Processing other than a connection error.

It is possible some of the code was unintentionally altered when fixing the COM port line. Delete the copy of the .pde file that you are running and replace it with a copy of the original .pde file for the collar.

11.0 Administrative Content

11.1 Works Cited

(Cover Image):

Cliparts.co. "Dog Head Silhouette Clip Art Images & Pictures - Becuo." Web. 9 December 2015

<<http://cliparts.co/clipart/2436333>>

(Accelerometer):

Freescale. "FXLS8471Q." Web. 10 November 2015

<<http://www.freescale.com/products/sensors/accelerometers/3-axis-accelerometers/2g-4g-8g-low-g-14-bit-digital-accelerometer:FXLS8471Q>>

GY. "GY-52 3 axis Accelerometer." Web. 9 November 2015

<<http://www.dx.com/p/gy-52-mpu-6050-3-axis-gyroscope-triaxial-accelerometer-6-axis-stance-tilt-module-for-arduino-148654?tc=USD&gclid=Cj0KEQiAKIWzBRDK1ayo-Yjt38wBEiQAI7NnP-tcvAB9Ur9-FWTvncbPGaNhfDIFO8TR9qP2qvokh6laAtLz8P8HAQ#.VmHROnarTIU>>.

Invensense. "Invensense MPU-9250" Web. 10 November 2015

<<http://www.digikey.com/Suppliers/us/invensense.page?lang=en&WT.srch=1>>

Kionix. "Kionix Accelerometers." Web. 8 November 2015

<<http://www.digikey.com/product-detail/en/KXCNL-1010-FR/1191-1035-1-ND/3880959?WT.srch=1>>

NXP. "Breakout Board for FXLS8471Q NXP Accelerometer." Web. 9 November 2015

<<http://www.nxp.com/products/sensors/accelerometers/3-axis-accelerometers/breakout-board-for-fxls8471q-freescale-accelerometer:BRKOUT-FXLS8471Q>>

(Wi-Fi):

GridConnect. "Tiny UART Embedded WiFi Module - HF-LPT100." Web. 9 November 2015

<<http://gridconnect.com/tiny-wifi-module-802-11-b-g-n-industrial-grade-temperature.html#>>

LinkSprite. "Cuhead WiFi Shield V2.0 for Arduino." Web. 9 November 2015.

<<http://store.linksprite.com/cuhead-wifi-shield-v2-0-for-arduino/>>

Mouser. "Olimex Wi-Fi Adapter" Web. 25 November 2015

<http://www.mouser.com/ProductDetail/Olimex-Ltd/MOD-WIFI-ESP8266/?qs=QGk6feVlqMkKopUWzCH4tA%3D%3D&gclid=Cj0KEQiAKIWzBRDK1ayo-Yjt38wBEiQAI7NnP6pACglG_JDltgdCS-yCRpXoY83PzaDp7AO7HWjbpLYaAj-48P8HAQ>

Olimex. "MOD-WIFI-ESP8266" Web. 9 December 2015

<<https://www.olimex.com/Products/IoT/MOD-WIFI-ESP8266/>>

Texas Instruments. "CC3100." Web. 25 November 2015
<<http://www.ti.com/product/cc3100>>

Tiny UART. "GC-HF-LPT100." Web. 23 November 2015
<https://gridconnect.com/tiny-wifi-module-802-11-b-g-n-industrial-grade-temperature.html?gdftrk=gdfV25227_a_7c1592_a_7c6907_a_7c1133&utm_source=google&utm_medium=CPC&utm_term=&utm_campaign=Shopping:%20%5bPLA%5d%20%20-%20All%20Products%20General%20All&mm_campaign=477cea803cb14c83d8a99b6c7d0cd349&keyword=&mkwid=sPwK9yrXV_dc%7Cpcrid%7C59302249153&gclid=Cj0KEQiAKlWzBRDK1ayo-Yjt38wBEiQAI7NnP3GDGIJvDg7mXXHWg8HV6heX8s8reOF4bk4Zthrf5UwaApWc8P8HAQ>

Wi-Fi Shield WISHIELD. "Wifi_shield_2_D4." Web. 25 November 2015
<<http://store.cutedigi.com/wifi-shield-wishield-v2-0-for-arduino/>>

(Microcontroller):

n.p.. Arrow. Arrow Electronics, Inc.. n.d.. Web. 15 September 2015
<<https://www.arrow.com/>>

Texas Instruments. "Beaglebone Black Development Board." Web. 8 November 2015
<<http://www.ti.com/tool/beaglebk#buy>>

---. "C2000 Real-Time Microcontrollers." Web. 8 November 2015
<<http://www.ti.com/lit/sg/sprb176z/sprb176z.pdf>>

---. "CC1110-CC1111." Web. 8 November 2015 <<http://www.ti.com/product/cc1110-cc1111>>

---. "CC430F5125." Web. 8 November 2015 <<http://www.ti.com/product/cc430f5125>>

---. "MSP430C092." Web. 8 November 2015 <<http://www.ti.com/product/msp430c092>>

---. "MSP430F2013." Web. 8 November 2015
<<http://www.ti.com/product/msp430f2013?keyMatch=MSP430F2013&tisearch=Search-EN-Everything>>

---. "MSP430F5131." Web. 8 November 2015 <<http://www.ti.com/product/msp430f5131>>

---. "MSP430F5529." Web. 8 November 2015 <<http://www.ti.com/product/MSP430F5529>>.

---. "MSP430FG4618." Web. 8 November 2015
<<http://www.ti.com/product/msp430fg4618?keyMatch=MSP430FG4618&tisearch=Search-EN-Everything>>

---. "MSP430G2553." Web. 8 November 2015
<<http://www.ti.com/product/MSP430G2553/description>>

---. "Tiva TM4C123GH6PM Microcontroller Datasheet." Web. 8 November 2015
<<http://www.ti.com/lit/ds/symlink/tm4c123gh6pm.pdf>>

---. "TM4C Microcontrollers." Web. 8 November 2015
<<http://www.ti.com/lit/sg/spmt285d/spmt285d.pdf>>

---. "TMS470MF03107." Web. 8 November 2015
<<http://www.ti.com/product/tms470mf03107>>

---. "RF430FRL154H." Web. 8 November 2015 <<http://www.ti.com/product/rf430frl154h>>

(GPS):

Adafruit. "Ultimate GPS Module - 66 channel w/10 Hz updates - MTK3339 chipset." Web. 7 September 2015 <<https://www.adafruit.com/products/790>>

Afrotechmods. "How to choose a battery: A battery chemistry tutorial." Online video clip. *YouTube*. YouTube, 14 Dec. 2014. Web. 8 Dec. 2015.

Garmin. "GPS 15x™." Web. 9 November 2015 <<https://buy.garmin.com/en-US/US/prod51048.html>>

SparkFun. "GPS Receiver - GP-2106 SiRF IV (48 Channel)." Web. 13 November 2015 <<https://www.sparkfun.com/products/10890>>

(Battery):

10TopTenReviews. "Battery Chargers and the Benefits of Rechargeable Batteries." Web. 10 September 2015 <<http://battery-charger-review.toptenreviews.com/battery-chargers-and-the-benefits-of-rechargeable-batteries.html>>

Adafruit. "Lithium Ion Polymer Battery - 3.7v 2500mAh." Web. 15 September 2015 <<https://www.adafruit.com/products/328>>

Electropaedia. "Primary (Non Rechargeable) Batteries." Web. 10 September 2015 <<http://www.mpoweruk.com/primary.htm>>

eHow. "Advantages and Disadvantages of Rechargeable Batteries." Web. 9 December 2015 <http://www.ehow.com/about_5397626_advantages-disadvantages-rechargeable-batteries.html>

Frequencycast. "Rechargeable Batteries vs Standard Batteries." Web. 9 December 2015 <<http://www.frequencycast.co.uk/rechargeablebatteries.html>>

Interstate Batteries. "What are the Advantages to Using Rechargeable Batteries?." Web. 11 September 2015 <<http://www.batteries-faq.com/activekb/questions.php?questionid=43>>

Isidor Buchmann. Battery University. Cadex Electronics Inc. 2003. Web. 15 September 2015 <<http://batteryuniversity.com/>>

Wikipedia. "Alkaline battery." Web. 8 December 2015 <https://en.wikipedia.org/wiki/Alkaline_battery>

---. "Nickel–cadmium battery." Web. 8 December 2015 <https://en.wikipedia.org/wiki/Nickel%E2%80%93cadmium_battery>

---. "Nickel–metal hydride battery." Web. 8 December 2015
<https://en.wikipedia.org/wiki/Nickel%E2%80%93metal_hydride_battery>

---. "Lithium-ion battery." Web. 8 December 2015 <https://en.wikipedia.org/wiki/Lithium-ion_battery>

---. "Lithium polymer battery." Web. 8 December 2015
<https://en.wikipedia.org/wiki/Lithium_polymer_battery>

(Heart-rate monitor):

Analog Devices. "AD8232." Web. 3 November 2015
<<http://www.analog.com/en/products/application-specific/medical/ecg/ad8232.html>>

Maxim Integrated. "MAX30100." Web. 5 September 2015
<<https://www.maximintegrated.com/en/products/analog/sensors-and-sensor-interface/MAX30100.html>>

SparkFun. "SparkFun Single Lead Heart Rate Monitor - AD8232." Web. 5 September 2015
<<https://www.sparkfun.com/products/12650>>

Texas Instruments. "AFE4400." Web. 5 September 2015
<<http://www.ti.com/product/afe4400>>

Wikipedia. "Electrocardiography." Web. 5 September 2015
<<https://en.wikipedia.org/wiki/Electrocardiography>>

(Internet of Things):

Bug Labs Inc.. dweet.io. Arrow, Ford, Renesas, Verizon. n.d.. Web. 10 November 2015
<<https://dweet.io/>>

Bug Labs Inc. freeboard.io. Web. 10 November 2015 <<https://freeboard.io/>>

n.p.. Wolfram Data Drop. n.d.. Web. 10 November 2015 <<https://datadrop.wolframcloud.com/>>

n.p.. Thing Speak. The MathWorks Inc. n.d.. 10 November 2015 <<https://thingspeak.com/>>

Wikipedia. "Electrocardiography." Web. 5 September 2015
<<https://en.wikipedia.org/wiki/Electrocardiography>>

Whatis. "Internet of Things (IoT)." Web. 5 September 2015
<<http://whatis.techtarget.com/definition/Internet-of-Things>>

11.2 Datasheets

Heart Rate Monitor:

<http://www.analog.com/media/en/technical-documentation/datasheets/AD8232.pdf>

Wi-Fi Module:

<http://www.ti.com/lit/ds/symlink/cc3100.pdf>

GPS Module:

<https://www.adafruit.com/datasheets/GlobalTop-FGPMMOPA6H-Datasheet-V0A.pdf>

Accelerometer:

<http://43zrtwysvxb2gf29r5o0athu.wpengine.netdna-cdn.com/wp-content/uploads/2015/02/MPU-9250-Datasheet.pdf>

Temperature Sensor:

<http://www.ti.com/lit/ds/symlink/tmp007.pdf>

Battery:

https://www.adafruit.com/datasheets/785060-2500mAh_specification_sheet.pdf

MCU:

<http://www.ti.com/lit/ds/symlink/tm4c123gh6pm.pdf>

11.3 Permission Letters:

Texas Instruments:

From: <support@ti.com>
Date: Mon, Nov 23, 2015 at 10:48 AM
Subject: RE: GEN, Email Technical Support, www.ti.com, AFE4400
To: 000stevh@gmail.com

Hello Steven,

No permission is needed, as long as you credit the correct sources. If you have any questions or concerns please contact us.

Regards,

Lisa Barrett
TI Customer Support
Americas Customer Support Center
[512-434-1560](tel:512-434-1560)

<http://e2e.ti.com/>

http://www-k.ext.ti.com/sc/technical_support/pic/americas.htm

TI makes no warranties and assumes no liability for applications assistance or customer product design. You are fully responsible for all design decisions and engineering with regard to your products, including decisions relating to application of TI products. By providing technical information, TI does not intend to offer or provide engineering services or advice concerning your designs.

Please do not delete the below Thread ID when replying to this email, doing so will delay our response to your inquiry

[THREAD ID:1-WMQ69M]

-----Original Message-----

From: 000stevh@gmail.com
Sent: 11/21/2015 12:10:24 PM
To: undisclosed-recipients:
Subject: GEN, Email Technical Support, www.ti.com, AFE4400

[This Email Sent From: Email Technical Support
<http://www.ti.com/general/docs/contact.tsp>]

[wfsegen]

[DATE / TIME (UTC): Sat, 21 Nov 2015 18:10:23 UTC]
[CUSTOMER'S REGIONAL LOCAL TIME: Saturday, November 21, 2015 1:10:23 PM]

[Name: steven heagney]

[Prefix: Mr.]
[First Name: steven]
[Last Name: heagney]
[Job Title:]
[Company: School]
[Email: 000stevh@gmail.com]
[Phone: [9545996986](tel:9545996986)]
[FAX:]
[Country: USA]
[Address1: 164 reserve circle, APT 208]
[Address2:]
[City: oviedo]
[State: FL]
[Postal Code: 32765]
[Part# or Description: AFE4400]
[Category: General Information]
[Application: Medical]
[Design Stage: Other]
[Estimated Annual Production: 1 units]
[Production Date: 11/21/15]

[Problem:

Hello, I am a student at the University Of Central Florida. I am part of a group project that is thinking about using one of your parts, the AFE4400, in our project. I would like permission from someone at TI that we can use pictures from your AFE4400 datasheet, such as the block diagram, in our paper report. If permission is given we will credit TI anywhere we use any pictures. Thanks for you time.]

MEDSBY:

From: "Guru Prasadn" <guruprasandh.g@gmail.com>
Date: Dec 8, 2015 10:58 AM
Subject: Re: Picture Permission
To: "steven h" <000stevh@gmail.com>
Cc:

Dear Steven,

We are glad to know that , our app 'ECG Simulator" is of some help. You can use our images. We would like to inform you that our website is under construction (might take two days). Once we update with new images and contents, we will inform you. then you can make use of the updated content. Once again thanks for your interest , we would like to know about your work and feedback for our app. We will be updating a new version of our app soon,

Regards,
G.Guru Prasadn
C.E.O & Founder
Medsby Healthcare & Engineering Solutions
[mob: +918015861849](tel:+918015861849)
www.themedsbv.com



On Tue, Dec 8, 2015 at 2:06 PM, steven h <000stevh@gmail.com> wrote:

Hello,

My name is Steven and I am a student at the University of Central Florida. I will be using the Medsby ECG simulator in a project and I was wondering if I could get permission to use some screenshots from your website in my project paper. I will credit your website where ever I use any pictures if I get permission to use them.

Thanks for you time.

Kionix Engineering:



John Chong <jchong@kionix.com>

1:09 PM (2 hours ago) ☆

to me ▾

Hi Steven,

Yes I give permission. Also, if you could, please send a link when you do publish.

Best regards,

John

On Wed, Dec 09, 2015 at 1:05 PM, Inquiries Inquiries <inquiries@kionix.onmicrosoft.com> wrote:

Hi Kionix Engineering,

University Steven ask a question.
Requester Location: Orlando,FL,United States of America
Email Address: 000stevh@gmail.com
Telephone:
Project Application:
Potential Annual Volume: 0

Questions/Comments:

Hello, I am a student at the University of Central Florida. I am working on a project that might be using a Kionix Accelerometer. I would like to ask for permission to use some pictures from your website featuring the Kionix Accelerometer. If permission is given, Kionix will be given credit.

Kionix Website Admin

SparkFun:

----- Forwarded message -----

From: "SparkFun Customer Service" <cservice@sparkfun.com>

Date: Dec 7, 2015 12:25 PM

Subject: Re: Parts Permission

To: <000stevh@gmail.com>

Cc:

DEC 07, 2015 | 10:24AM MST

Nick M replied:

Hello-

As long as SparkFun is credited, you're more than welcome to use our pictures! Please let me know if there is anything further I can do to help!

Nick Miranda

SparkFun Electronics

Distributor and Customer Service

[303-945-2984 x 607](tel:303-945-2984)

DEC 07, 2015 | 06:33PM MST

Original message

steven wrote:

Hello,

I am a student at the University of Central Florida. I am working on a project and plan on using some parts from your website. I was wondering if I could get permission from you to use pictures and information from your website about some of your parts such as the single lead heart rate monitor. If I get permission, I will credit sparkfun where ever I use information from their website. Thanks for your time.

Battery University:



BatteryU <BatteryU@cadex.com>

To: Stephanie Heagney,



Mon 12/7/2015 1:56 PM

Hi Stephanie,

Yes you may use the material as requested. Please cite sources where appropriate.

Regards,

John Bradshaw - Marketing Communications Manager
Cadex Electronics Inc. | www.cadex.com
Vancouver | Minneapolis | Frankfurt
Tel: +1 604 231-7777 x319 | Toll Free: 1-800 565-5228

Follow us on Twitter: twitter.com/cadexelectronic
Join us on Facebook: facebook.com/cadexelectronics
Add us on Google+: plus.google.com/+Cadex

>>> Stephanie Heagney <stephieh@knights.ucf.edu> 12/5/2015 9:22 PM >>>



Stephanie Heagney

To: BatteryU@cadex.com,



Sun 12/6/2015 12:22 AM

Sent Items

Hello,

I am a senior student at the University of Central Florida and I am in charge of the battery power for our project. I'm using Battery University for research and I just wanted to ask you if it's ok to use some of your pictures from your website in my report. I will cite all your information properly of course.

Thanks,
Stephanie

Adafruit:



adafruit@gmail.com on behalf of Adafruit Industries <support@adafruit.com>

👍 Reply all | ▾

To: Stephanie Heagney; ▾

Wed 12/2/2015 10:38 PM

Totally OK

On Wed, Dec 2, 2015 at 10:32 PM, Stephanie Heagney <support@adafruit.com> wrote:

security token :
contactname : Stephanie Heagney
email address : stephieh@knights.ucf.edu
contact us 2 section : press
useragent string : Mozilla/5.0 (Windows NT 6.2; WOW64; rv:42.0)
Gecko/20100101 Firefox/42.0
message text : Hello,

I don't have a Press/Media inquiry, I just didn't see any category this request would fit under. I am a senior student at the University of Central Florida and I'm using Adafruit's Ultimate GPS in my project. I just wanted to ask you if it's ok to use some of your pictures from your website and datasheet in my report. I will cite all your information properly of course.

Thanks,
Stephanie

Client IP: 108.64.167.43

ANALOG DEVICES:

From: <cic.americas@analog.com>
Date: Dec 7, 2015 7:59 AM
Subject: re:Technology Pictures Permission (Case#: C15LF0038)
To: <000stevh@gmail.com>
Cc:

Hi Steven,
We received your voice mail and email. Your question has been forwarded to legal for reply.
Best Regards,
Deb
ADI Tech Support

To: <cic.americas@analog.com>
cc:
From: steven h <000stevh@gmail.com>
Date: 12/06/2015 05:55:24 PM
Subject: Technology Pictures Permission

Hello,

I am a student at the University of Central Florida. I am working on a group project that might use one of your products, the AD8232, in our project. I was wondering if I could get permission to use pictures from the AD8232 data sheet, such as block diagrams and pin layouts, in our project report. If permission is granted to us, we would credit analog devices where ever we use any pictures. Thanks for your time.

Gridconnect:

Chat Transcript
info: Thank you for choosing to chat with us. An agent will be with you shortly. info: You are now chatting with Brittney. Brittney: Hi Steven.
steven heagney: Hello, how are you? Brittney: Good. Thank for asking. How are you?
steven heagney: Im good, I don't know if you can answer my question or not Brittney: Well, you are lucky because I happen to be the marketing manager here.
Brittney: What pictures are you looking for? Anything specific?
steven heagney: My lucky day, the picture is of the Tiny UART wifi module HF-LPT100 steven heagney: it is in the store section Brittney: Yes, feel free to use that. Are the pictures on the website good enough for your project? If not, I can email you the original pictures which may be higher quality.
steven heagney: Would that be a lot of trouble for you? I would like the better quality but I dont want to put you through a lot of extra work Brittney: Not a problem. Happy to do it. Is your email address 000stevh@gmail.com ? steven heagney: Yes it is, thank you so much! Brittney: Perfect. Can I help you with anything else today?
steven heagney: No you have been super helpful already! Thanks again. Brittney:

NXP:

Francisco:

Hello Steven.

steven:

Hello

Francisco:

Thank you for contacting NXP Semiconductors.

Francisco:

How are you?

steven:

I am good, I just have a quick question

steven:

I am a student at the University of central Florida, I am working on a project and I might be using some devices from NXP

steven:

I would like to use some pictures of the parts from the NXP website but I need to get permission first

steven:

Could you give permission? Or should I email somebody else?

Francisco:

It depends on the pictures, Steven.

Francisco:

Which type of images are you going to use?

steven:

The pictures from the parts on the NXP store

Francisco:

Do you have the link?

Francisco:

Of the pictures.

Francisco:

Just to confirm.

steven:

<http://www.nxp.com/products/sensors/accelerometers/3-axis-accelerometers/breakout-board-for-fxls8471q-freescale-accelerometer:BRKOUT-FXLS8471Q>

Francisco:

Checking.

steven:

So I want to use a picture of that accelerometer

steven:

Of course I would give credit to NXP website saying that is where I got it from.

Francisco:

It shouldn't be a problem Steven.

Francisco:

That images are in public domain.

Francisco:

You don't need to write to anybody.

steven:

Ok great, I just wanted to make sure before I took any, thanks for the help

Francisco:

You're very welcome Steven.

Francisco:

Have a great day.

steven:

You too thanks.

Chat session ended. Goodbye.